



In silico analyses and design of chimeric proteins containing epitopes of *Bartonella henselae* antigens for the control of cat scratch disease

Jênifer Malheiros Gonçalves^{1,2} · Thayná Laner Cardoso¹ · Stella Buchhorn de Freitas^{1,2} · Rafael Woloski² · Amilton Clair Pinto Seixas Neto¹ · Luciano da Silva Pinto² · Elba Sampaio de Lemos³ · Daiane Drawanz Hartwig^{1,2,4} 

Received: 27 June 2022 / Revised: 24 October 2022 / Accepted: 31 October 2022 / Published online: 16 November 2022
© The Author(s), under exclusive licence to Springer-Verlag GmbH Germany, part of Springer Nature 2022

Abstract

Bartonella henselae is a Gram-negative bacterium that causes cat scratch disease (CSD), as well as bacteremia, endocarditis, and other clinical presentations. CSD remains one of the most common infections caused by bacteria in the genus *Bartonella*, and it is transmitted to humans through a scratch or cat bite. Vaccination and more efficient diagnostic methods would represent a promising and sustainable alternative measure for CSD control in humans and animals. Here, we described the in silico analyses and design of three recombinant chimeric proteins (rC1, rC2, and rC3), for use in the control of CSD. The chimeras were constructed with epitopes identified from the sequences of the GroEL, 17 kDa, P26, BadA, Pap31, OMP 89, and OMP 43, previously described as the most important *B. henselae* antigens. The rC1, rC2, and rC3 were expressed and purified using a heterologous system based on *Escherichia coli* and reacted with antibodies present in the sera of humans naturally infected. The chimeric proteins were used to immunize mice using Freund adjuvant, and the humoral immune response was evaluated. Animals immunized with rC1 and rC3 showed a significant IgG antibodies response from the 28th day ($P < 0.05$), and the animals immunized with the rC2 from the 35th day ($P < 0.05$) remained until the 56th day of experimentation, with a titer of 1:3200 ($P < 0.05$), 1:1600 ($P < 0.05$) and 1:1600 ($P < 0.05$) from rC1, rC2, and rC3, respectively. Significant production of IgA and IgG1 isotype was detected in animals immunized with rC1 and rC2 proteins. Additionally, analysis using 13 serum samples from naturally infected patients showed that the proteins are recognized by antibodies present in sera, reinforcing the possibility of using these chimeras for CSD control.

Key points

- The recombinant chimeras were expressed in *Escherichia coli* with 37 kDa (rC1), 35 kDa (rC2), and 38 kDa (rC3).
- Animals immunized with rC1, rC2, and rC3 showed significant antibody response.
- The chimeras were recognized by the sera of naturally infected patients.

Keywords In silico analysis · Recombinant protein · Vaccine · Diagnosis

Introduction

Bartonella henselae is a Gram-negative, fastidious, facultative intracellular bacterium (Gil et al. 2013). It is considered an important medical species because it infects cats (reservoirs) and humans (accidental hosts) (Breitschwerdt 2017). The

transmission of *B. henselae* to cats occurs directly through contact with fleas (*Ctenocephalides felis*) or through stool-infected wounds from these fleas, as well as through ticks (suggested as potential vectors) (Regier et al. 2016; Breitschwerdt 2017). Cats infected with *B. henselae* are often clinically asymptomatic, although they suffer from recurrent bacteremia for long periods. In humans, *B. henselae* is the etiological agent of cat scratch disease (CSD), a frequently self-limiting infection in immunocompetent individuals, but it can be fatal in immunocompromised individuals. Transmission to humans occurs through bites or scratches from flea-infested cats, which eliminate the bacteria in their stool, or directly through contaminated blood (Regier et al. 2016).

Jênifer Malheiros Gonçalves and Thayná Laner Cardoso contributed equally to this work.

✉ Daiane Drawanz Hartwig
daianehartwig@gmail.com

Extended author information available on the last page of the article

Bartonella species are found worldwide and are more pronounced in areas where conditions are more favorable for arthropod vectors, especially fleas (Pennisi et al. 2013). In the USA, CSD is one of the most common zoonoses, resulting in more than 25,000 cases per year. In addition, seropositivity levels in healthy individuals are 19.6% in China, 16% in Sweden, and 8.7% in Spain (Kwon et al. 2017). Although there are some prevalence studies in Brazil, these may be few and may not portray reality in Brazil. However, studies have indicated that the circulation of *Bartonella* species is common. Serologies show a prevalence of 15–56.6% in cats (Crissiuma et al. 2011; Kitada et al. 2014; Fontalvo et al. 2017) and 3.2–23.5% in humans (Pitassi et al. 2015; Vieira-Damiani et al. 2015). Molecular methods have revealed the prevalence to be 2.2–90.2% in cats (Staggemeier et al. 2014; Malheiros et al. 2016; Drummond et al. 2018) and 3.2–100% in humans (Lamas et al. 2013; Favacho et al. 2014; Pitassi et al. 2015; Vieira-Damiani et al. 2015). With direct detection or antibody research, *B. henselae* has already been identified in cats in the states of Maranhão (de Oliveira Braga et al. 2012), Pernambuco (Fontalvo et al. 2017); Bahia (Costa et al. 2014), Mato Grosso (Miceli et al. 2013), Mato Grosso do Sul (André et al. 2016), Rio de Janeiro (Crissiuma et al. 2011; Kitada et al. 2014; da Silva et al. 2018), São Paulo (Bortoli et al. 2012; Drummond et al. 2018), and the Rio Grande do Sul (Staggemeier et al. 2014; Malheiros et al. 2016). Similarly, the microorganism has been found in humans in the states of Rio de Janeiro (Lamas et al. 2013; Favacho et al. 2014), São Paulo (Vieira-Damiani et al. 2015; Drummond et al. 2018), and Minas Gerais (Da Costa et al. 2005). Interestingly, studies conducted in Brazil have demonstrated the presence of *Bartonella* spp. bacteremia in asymptomatic blood donors, reinforcing the need for evaluation of *Bartonella* blood transmission (Pitassi et al. 2015; Vieira-Damiani et al. 2015).

The prevention of *B. henselae* infection in humans, as well as the reduction of morbidity and mortality, is based on the control of infection in the cat population. However, infection in cats is difficult to control, as most cats are asymptomatic (Greene et al. 1996; Regnery et al. 1996; Kordick and Breitschwerdt 1997). No successful vaccine against *B. henselae* has been developed to date. The selection of appropriate *B. henselae* antigens is critical for the development of a successful vaccine. Additionally, the precise diagnosis of infection (reservoirs and hosts) can be challenging, especially in patients with chronic and long-term infections. Conventional techniques for detecting bacteria or antibodies against bacteria, such as Enzyme-linked Immunosorbent Assay (ELISA), Western blotting (WB), Indirect Immunofluorescence Assay (IFA), and Polymerase Chain Reaction (PCR), have limitations (Breitschwerdt 2017). IFA is the gold standard serological method for detecting antibodies against *B. henselae*, and it uses antigens from the entire

bacterial cell co-cultivated in Vero cells, which have good sensitivity, but are expensive, laborious, and can have cross-reactions (Ferrara et al. 2014) with *B. quintana*, *Coxiella burnetii*, *Chlamydomphila pneumoniae*, *Ehrlichia chaffeensis*, *Mycoplasma pneumoniae*, *Escherichia coli*, *Rickettsia* spp., *Treponema pallidum*, *Bordetella pertussis*, and *Borrelia* spp. (Jost et al. 2018). In the ELISA test, whole-cell antigens are used, but they have low sensitivity and specificity (Ferrara et al. 2014).

Outer membrane proteins (OMPs), which are an interface between the bacterium and host cells, may be targets in the development of diagnostic tests and vaccines. *B. henselae* OMP 43 and OMP 89 proteins play an important role in the adherence and invasion of host cells (Li et al. 2011). Adhesin BadA, another OMP, may also be another important target, as this protein is recognized by antibodies from patients infected with *B. henselae* (Wagner et al. 2008). In addition, the use of recombinant proteins has been evaluated, and known antigenic proteins such as GroEL (McCool et al. 2008), 17 kDa (Loa et al. 2006; Hoey et al. 2009; Ferrara et al. 2014), Pap31 (Angkasekwina et al. 2014), and P26 (Werner et al. 2008) have already been tested in serological assays. However, all evaluated proteins were used isolated, and in some of them, sensitivity was limited. This fact reinforces the need for the development of new alternatives, as chimeric proteins may be more immunogenic antigens than whole antigens. In this study, we identified immunogenic epitopes on the proteins GroEL, 17 kDa, P26, BadA, Pap31, OMP 89, and OMP 43 of the *B. henselae*, combined them in silico to produce three recombinant chimeras and assessed the use in diagnosis and vaccine development to control of CSD.

Materials and methods

Antigens selection, protein sequences, and epitopes prediction

For choosing targets, we searched the PubMed database (<http://www.ncbi.nlm.nih.gov/pubmed/>) to identify *B. henselae* OMPs. The search terms and the number of studies found were as follows: *Bartonella henselae* proteins (19); *Bartonella henselae* outer membrane protein (35); *Bartonella henselae* antigens (151); *Bartonella henselae* recombinant proteins (30); and *Bartonella henselae* immunogenic proteins (9). The summary of these studies was read, and all studies that identified *B. henselae* antigenic proteins were read in full to identify the targets. The criterion adopted for protein selection was the highest frequency of citation in the articles. Thus, the following proteins were selected: GroEL, 17 kDa, P26, BadA, Pap31, OMP 89, and OMP 43.

GroEL (Accession no. CUH91264), 17 kDa (Accession no. AAF00943), P26 (Accession no. ABB8349), BadA (Accession no. AAT69970), Pap31 (Accession no. AAC39274), OMP 89 (Accession no. CAF27432), and OMP 43 (Accession no. CAF27934) protein sequences were recovered from GenBank, NCBI (<http://ncbi.nlm.nih.gov>) in FASTA format and used in further analysis. The InterPro software (<http://www.ebi.ac.uk/interpro/search/sequence/>) was used for the functional annotation of proteins.

In silico analysis was performed using predictors available online to identify the linear B cell epitopes in antigens of *B. henselae*. The selected regions contained 1 to 5 epitopes with 11 to 44 amino acids. The predictors used were as follows: Immune Epitope Database and Analysis Resource (www.iedb.org) and Sequential B-Cell Epitope Predictor 2.0 (<http://www.cbs.dtu.dk/services/BepiPred/>). The choice of two predictors served to increase the reliability of the selected epitopes. The selected epitopes were analyzed for the presence of orthologs in *B. henselae* using the Basic Logical Alignment Search Tool (<https://blast.ncbi.nlm.nih.gov/Blast.cgi>).

Similarity assessment

To evaluate homologs of GroEL, 17 kDa, P26, BadA, Pap 31, OMP 89, and OMP 43 proteins in the proteomes of *Homo sapiens* (UniProt Proteome: UP000005640) and *Felis catus* (UniProt Proteome: UP000011712), two of the main species affected by *B. henselae*, UniProt BLASTP (www.uniprot.org/BLAST) and NCBI BLASTP (<https://blast.ncbi.nlm.nih.gov/Blast.cgi?PAGE=Proteins>) were performed. The similarity assessment was performed both for the chimeras and for the entire proteins used in their construction.

Chimeric design, prediction of the secondary structure of mRNA, and three-dimensional protein structure

After the selection of the most promising epitopes for the composition of the multi-epitope chimeras, the epitopes were randomly distributed and combined for chimera construction. These were ligated by 3× glycine and 1× serine linkers. The chimeric constructions obtained were sent for chemical synthesis by the company GenOne Biotechnologies (Rio de Janeiro, Brazil) and the gene sequence was delivered and cloned into the pAE vector. The DNA coding sequences of the multi-epitope chimeric proteins have been deposited at GenBank under the accession numbers OP021759 (rC1), OP021760 (rC2), and OP021761 (rC3). The RNA-Fold software (<http://rna.tbi.univie.ac.at/cgi-bin/RNAWebSuite/RNAfold.cgi>) was employed to predict the secondary structure of RNA. This software predicts minimum free energy structures and base pair probabilities from single

RNA sequences. The sequences resulting were submitted to analysis on the I-TASSER server (Yang et al. 2014) for the prediction of its three-dimensional structure. The model generated with the largest C-score was used for structural quality analysis using the QMEAN6 program (Arnold et al. 2006). Three-dimensional structures were visualized using the PyMol v1.8.4.0 tool (Janson et al. 2017).

Physicochemical parameters, antigenicity, and solubility

The ProtParam online server (<http://us.Expasy.org/tools/protparam>) was used to evaluate physicochemical parameters, including amino acid composition, theoretical isoelectric point, molecular weight (MW), in vitro and in vivo half-lives, aliphatic index, instability index, grand average of hydropathicity (GRAVY), and the total number of positive and negative residues. Antigenicity was predicted by using the VaxiJen server (<https://omictools.com/vaxijen/tool>). VaxiJen is used to predict protective antigens and subunit vaccines (Doytchinova and Flower 2007). Protein solubility was predicted by using the SOLpro server at <http://scratch.proteomics.ics.uci.edu/>. SOLpro is used to predict the propensity of a protein to be soluble after overexpression in *E. coli* by using a support vector machine architecture based on multiple representations of the primary sequence (Magnan et al. 2009).

Production of recombinant chimeras

Sequences of the identified epitopes were used for three-chimera in silico design. These sequences were later sent to GenOne (Rio de Janeiro, Brazil) for chemical synthesis, and the genes were cloned to the expression vector pAE and called as follows: pAE/*Chimera*1, pAE/*Chimera*2, and pAE/*Chimera*3. The vectors were transformed into One Shot™ BL21 Star™ (DE3) chemically competent *E. coli* (catalog number: C601003, Invitrogen) strains and cultivated in 500 mL of Luria–Bertani broth at 37 °C at 200 rpm until reaching $DO_{600nm} = 0.5–0.7$. Expression was then induced with 1 mM of isopropyl-β-D-thiogalactopyranosid. The cultures were kept under the same incubation conditions for another 3.5 h and then subjected to centrifugation (7000×g, 4 °C, 15 min). The cells were then suspended in a solubilization buffer (8 M urea, 200 mM NaH₂PO₄, 0.5 M NaCl, and 5 mM imidazole, pH 8.0) and incubated at room temperature at 60 rpm for 18 h. Purification was performed by chromatography by using HisTrap FF (GE Healthcare) columns loaded with nickel. The purified proteins were dialyzed against phosphate-buffered saline (PBS) 1X in 16 steps for five days at 4 °C. The concentration of proteins was determined through the BCA Protein Assay kit (Pierce, USA), and the proteins were stored at –20 °C.

The purity and size of proteins were analyzed in sodium dodecyl sulfate–polyacrylamide gel electrophoresis (SDS-PAGE 15%) stained with Coomassie Blue. The expression of recombinant chimeras was confirmed by WB, by employing an anti-6×His-tag monoclonal antibody (Sigma-Aldrich, USA). Briefly, the chimeric proteins were separated by 15% SDS-PAGE and electro-transferred onto Hybond™ ECLTM (Amersham Biosciences) nitrocellulose membranes. The membranes were blocked with PBS-FBS 1% (PBS with 1% [v/v] fetal bovine serum) and reacted with the anti-6×His-tag monoclonal antibody (Sigma-Aldrich, USA) at 1:100 dilution in PBS. Then, a goat anti-mouse Ig peroxidase conjugate (Sigma-Aldrich, USA) was added at 1:4000 dilution. Incubations were performed for 1 h at room temperature in agitation (50 rpm), and washes with PBS-T (PBS with 0.05% [v/v] Tween 20) were performed between all steps. Then, reactions were developed with a chromogen/substrate solution (6 mg diaminobenzidine, 0.03% nickel sulfate, 50 mM Tris–HCl, pH 8.0, and 0.03% hydrogen peroxide) for the visualization of protein bands.

Evaluation of antigenicity of recombinant chimeras

A serum sample of a human naturally infected with *B. henselae* and previously tested by IFA for *B. henselae* was provided by the Division of Dermatology, Department of Medicine of the State University of Campinas, Campinas, São Paulo, Brazil. This serum sample was used for evaluating the antigenicity of recombinant chimeras produced by Western blotting (WB). Briefly, the purified chimeras were submitted to 15% SDS-PAGE and electro-transferred onto a Hybond™ ECLTM (Amersham Biosciences) nitrocellulose membrane. The membranes were blocked with PBS-FBS 1% at 4 °C overnight and washed three times with PBS-T and incubated with human serum at 1:50 dilution (at room temperature for 1 h, under the agitation of 50 rpm). The membrane was then washed three times with PBS-T and incubated with the secondary human anti-IgG antibody conjugated to peroxidase at 1:1000 dilution in PBS-T. Reactions were developed with a chromogen/substrate solution (6 mg diaminobenzidine, 0.03% nickel sulfate, 50 mM Tris–HCl, pH 8.0, and 0.03% hydrogen peroxide) for the visualization of protein bands.

Immunization of mice

Eight male BALB/C mice, 6–8 weeks old, were used in this study. All animals were accommodated in polypropylene boxes, with two animals per box. To experiment, the animals were separated into four groups with two animals each. The groups were (1) animals immunized with rC1 plus adjuvant, (2) animals immunized with rC2 plus adjuvant, (3) animals immunized with rC3 plus adjuvant, and

(4) animals inoculated with the protein diluent (PBS 1X) plus adjuvant. The mice immunization was carried out with the intraperitoneal inoculation of 100 µg of rC1, rC2, and rC3 in the animals on days 0, 14, 21, 28, 35, 42, 49, and 56. Animals inoculated with PBS were submitted to the same immunization protocol applied to animals immunized with recombinant chimera. The first dose was performed with the addition of complete Freund's adjuvant (Sigma-Aldrich, USA) in a 1:1 ratio, while for the following doses Freund's incomplete adjuvant (Sigma-Aldrich, USA) was used. Before each inoculation, blood samples were collected through retro-orbital bleeding from the animals and subjected to centrifugation (3,000×g, 5 min) to obtain the serum. On the 56th day of experimentation, all animals were euthanized to obtain whole blood via cardiac puncture, and the serum was obtained as described. All serum samples collected were maintained at –20 °C.

Evaluation of the humoral immune response in mice

Antibody responses were monitored by indirect enzyme-linked immunosorbent assay (ELISA) using rC1, rC2, and rC3 as antigens. Each well was coated with 50 ng of each antigen diluted in carbonate-bicarbonate buffer, pH 9.6. The ELISA plates were washed three times with PBST (PBS with 0.05% (v/v) Tween 20) and then blocked. Mice sera (diluted 1:100) was added for 1 h at 37 °C, and then the plates were washed three times with PBST. Anti-mouse IgG antibody peroxidase-conjugated (Sigma-Aldrich), at 1:6,000 dilution, was added, incubated at 37 °C for 1 h, washed five times with PBST, and the reaction was visualized with o-phenylenediamine dihydrochloride (Sigma-Aldrich) as well as hydrogen peroxide. The reaction was stopped by the addition of 0.1 M sulfuric acid, and absorbance was determined at 492 nm using a Multiskan MCC/340 ELISA plate reader (Titertek Instruments, USA).

Antibodies titration

An indirect ELISA assay was performed to standardize the antibody production in mice. The 96-well polystyrene plates (Cralplast, Brazil) were coated with 50 µg of rC1, rC2, or rC3 per well and maintained at 4 °C, overnight. The addition of the sera anti-chimeras collected on the 56th day of experimentation was carried out employing a twofold serial dilution, varying from 1:50 to 1:1640. The sera of the animals were analyzed in pools for all the groups. After incubation (1 h, 37 °C), an anti-mouse IgG monoclonal antibody peroxidase-conjugated (Invitrogen, EUA) was added at 1:6000 dilution. The reaction was visualized using a developing buffer (0.1 M citrate phosphate pH 4 buffer, 0.2 mg/mL o-phenylenediamine dihydrochloride (OPD), and 0.03% hydrogen peroxide) and it was stopped with the addition

of 2 M H₂SO₄ solution. The optical density reading was performed on EZ read 400 Microplate Reader (Biochrom, England) with a wavelength of 492 nm.

Antibodies isotyping

The antibodies produced were evaluated for the different isotypes using a Mouse Monoclonal Antibody Isotyping Reagents kit (Invitrogen, USA). The following isotypes were evaluated: IgM, IgA, IgG1, IgG2a, IgG2b, and IgG3. For this, 96-well polystyrene plates (Cralplast, Brazil) were coated with 100 µl of rC1, rC2, or rC3 diluted in carbonate-bicarbonate buffer (pH 9.6), totaling 50 µg of proteins per well. The plate was incubated overnight (4 °C) and, after the end of the incubation, 60 µl of the pool of sera (1:1 diluted in PBS 1X) from the immunized animals (day 56) was added. Pools of sera from animals collected on day 0 and animals inoculated with PBS were used as controls. The sera were incubated for 1 h at 37 °C, and after the incubation period, 100 µl of each of the specific isotype reagents was added (1:1000 in PBS, 30 min at room temperature). At the end of incubation, the anti-goat IgG antibody peroxidase-conjugated was added (1:5000 in PBS, 15 min at room temperature). The reaction development was done using 0.1 M citrate phosphate buffer (pH 4.0), 0.2 mg/mL o-phenylenediamine dihydrochloride (OPD), and 0.03% hydrogen peroxide. The reaction was stopped with a 2 M H₂SO₄ solution. Between each step, the wells were washed with PBS-T solution. The results were determined on EZ read 400 Microplate Reader (Biochrom, England) at 492 nm.

Evaluation of the antigenicity of recombinant chimeras by ELISA

To prove that the recombinant chimeric proteins are antigenic, the recognition of the chimeras by the antibodies present in the serum of naturally infected patients was evaluated. For this, an indirect ELISA was performed with the recombinant chimeras, which were confronted with 13 human sera positive for *B. henselae*, previously tested by IFA, with titers ranging between 64 and 8192, all of the convalescent phase. These sera were provided by the Laboratory of Hantaviruses and Rickettsiosis (LHR) of the Oswaldo Cruz Foundation (FIOCRUZ, RJ, Brazil). For the ELISA, 96-well plates were sensitized with 50 ng of each recombinant chimera. Afterward, the plates were incubated at 4 °C for 16–18 h. At the end of the incubation, the wells were blocked with PBS-T/BSA solution [1X PBS plus 0.05% (v/v) Tween 20 and 1% (w/v) bovine serum albumin] for 1 h. Subsequently, the sera were diluted in PBS-T 1X (pH 7.4) at a ratio of 1:100 and added to the wells, and the plates were kept at 37 °C for 1 h. Peroxidase-conjugated anti-human IgG antibodies (Sigma-Aldrich, USA) were added at a 1:10,000

dilution. The plates were kept at 37 °C for 1 h. Visualization of the result occurred through the addition of phosphate-citrate buffer (pH 5.3) plus 0.2 mg/mL of o-phenylenediamine dihydrochloride (OPD) and 0.03% of H₂O₂. A 2 M H₂SO₄ solution was used to stop the reaction. The quantification of the reaction was performed in a spectrophotometer with a wavelength of 492 nm. Between each of the described ELISA steps, the plates were washed four times with PBS-T solution (PBS plus 0.05% Tween 20). As a positive control, a human serum positive for *B. henselae* was used, and as a negative control, a human serum negative for *B. henselae* was used. The tests were repeated twice, on different days and in duplicate.

Statistical analysis

All assays were performed at least in triplicate. Data were analyzed using the software GraphPad Prism version 6.01 (GraphPad Inc., San Diego, CA, USA) by two-way ANOVA and Tukey test. A *P* < 0.05 was considered statistically significant and the results are expressed as mean ± standard deviation.

Results

In silico analyses

Among the several antigenic proteins reported in the literature, we selected seven from in silico analyses and determined their function through the InterPro software (Table 1). Subsequently, in silico analyses of the proteins were performed to seek epitopes involved in antibody production. Through alignment and search for similarity with the BLAST tool, we identified that these epitopes had 100% identity with those from *B. henselae*. Next, all the selected epitopes were randomly distributed and combined for chimera construction (Table 2) to form three distinct

Table 1 Proteins selected and functional annotation extracted from the *InterPro* software

Antigen	Molecular function/Biological process
GroEL	Protein refolding and folding/ATP-binding protein
17 kDa	UNK
P26	UNK
BadA	Pathogenesis
Pap31	Transmembrane transport/porin activity
OMP 43	UNK
OMP 89	Assembly membrane

GroEL, chaperone; *P26*, major immunodominant antigen; *BadA*, *Bartonella* adhesin A; *Pap31*, heme-binding protein; *OMP*, outer membrane protein; *UNK*, unknown

Table 2 Selected epitopes of the GroEL, 17 kDa, P26, BadA, Pap31, OMP89, and OMP43 proteins

Antigen	Initial position of the epitope	Final position of the epitope	Amino acid sequence
GroEL	322	346	kvniskentiidgagqkseinarvn
	351	373	vqieettsdydreklqerlakla
	382	418	ggatevevkekkrvddalnatraaveegivaggta
17 kDa	1	115	tatltdeyykkalentqkldvaksqtaesiyestatqkankiddinnqlanlkadtktkpeqlqal- qieltllqaqlqadtikiqslamiqakdtktkeelreeqtqkkhedlqkq
	32	49	tqdktaqkaladnnksmn
	57	68	nngiqandlqts
	70	87	lsiyqsnpnkdhekknng
	P26	103	109
P26	118	123	ftnantkpfyqe
	126	137	tgaknlsqnsqgvnyskgshgsivlsgdddfcgady
	BadA	34	142
BadA	5	19	phevaptvisapafs
	25	61	Iggqvgnfsskveitdpnkdklfskddtpkpsgfmq
	Pap31	64	71
Pap31	82	107	davwadredaktssaeaiqqdeletf
	432	443	vternlggrgq
	449	457	glgagqeks
	464	473	fvdpyflgyr
	OMP 89	480	495
505		509	ndqls
516		537	yiqeeydfgkkydlsketdire
32		49	tqdktaqkaladnnksmn
57		68	nngiqandlqts
OMP 43	70	87	lsiyqsnpnkdhekknng
	103	109	lsnagki
	118	123	vnsvhg
OMP 43	126	146	ftnantkpfyqearkkaiaea

recombinant chimeric proteins: chimera 1 (rC1), chimera 2 (rC2), and chimera 3 (rC3) (Fig. 1).

The RNAfold software was used for predicting the secondary structures of the mRNA of each chimera. The minimum free energy of the secondary mRNA structure was $\Delta G = -278.00$, -328.00 , and -299.00 kcal/mol for rC1, rC2, and rC3, respectively. All structures lacked hairpins or pseudo-nodes on the side of the 5' ends (Fig. 1).

For evaluating physicochemical properties, we used the ProtParam online server to evaluate amino acid composition, theoretical isoelectric point, molecular weight, in vivo half-life, aliphatic index, instability index, extinction coefficient, grand average of hydropathicity, and the total number of positive and negative residues. Solubility was evaluated by using the Solpro server. The antigenic potential was evaluated by using the VaxyJen server; it is the first server for

alignment-independent prediction of protective antigens of bacterial, viral, and tumor origin. All these parameters are presented in Table 3.

Table 4 presents the quality analysis of the model generated for the chimeras. The RMSD and TM-score values were calculated during modeling by the I-TASSER server. QMEAN6-score, Ramachandran plot, Z-score, and DFIRE-energy values were calculated in the QMEAN analysis program hosted by the SwissProt database. QMEAN analysis program also provides visual quality analysis of the evaluated model. The analysis of local error by residue showed a general predominance of residues, indicating a low-quality prediction of the three-dimensional position (data not shown). The least reliable regions are the loopings and the 6 × His tail, places that are difficult to predict because of the lack of a defined standard secondary structure.

Fig. 1 Final sequence of the rC1 (A), rC2 (B) and rC3 (C). Linker: GGGG. The ideal secondary structure of the mRNA of rC1, rC2 and rC3 in the point support notation with a minimum free energy of -278.60 (A), -328.20 (B), and -278.60 (C) kcal/mol are given above, respectively. The predicted structure has no hairpin and pseudo node at the 5' mRNA site

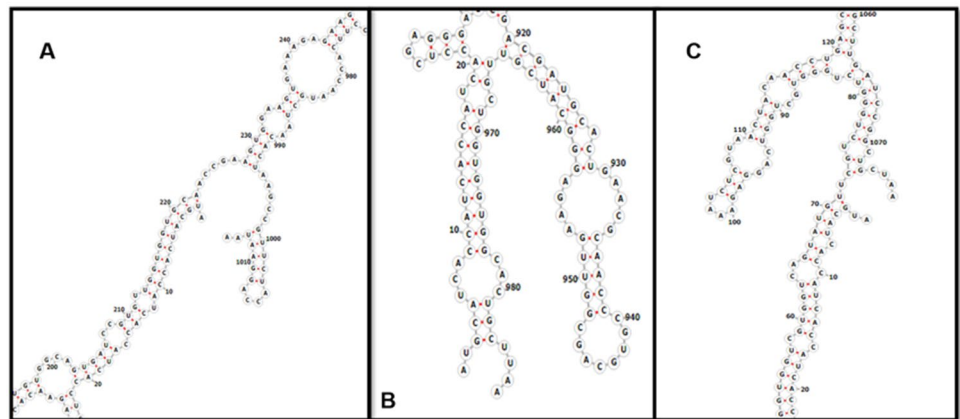
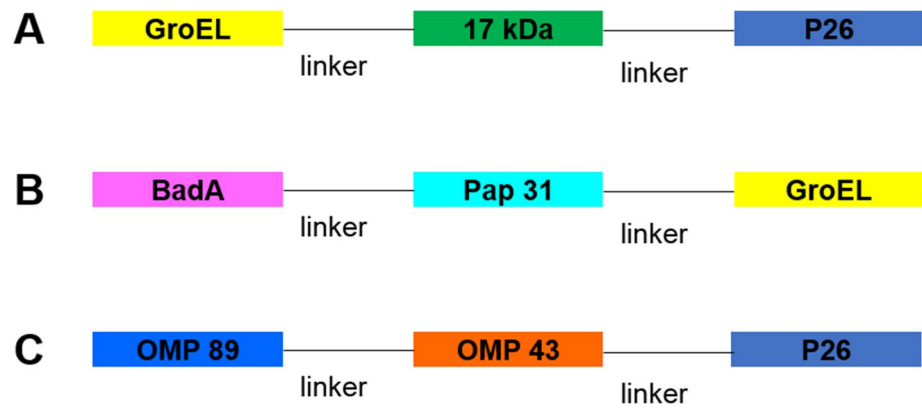

Table 3 Evaluation of physicochemical parameters of chimeras

ExPASy	rC1	rC2	rC3
Amino acids	337	328	346
Molecular mass (kDa)	36,900.11	34,643.09	38,220.29
Isoelectric point (Pi)	6.57	5.12	9.14
Negative residues (Asp + Glu)	45	46	34
Positive residues (Arg + Lys)	43	33	40
Half Life (h) <i>E. coli</i>	> 10	> 10	> 10
Index of instability	32.3 (stable)	34.30 (stable)	23.67 (stable)
Aliphatic index	80.27	67.77	71.39
Average hydropaticity (Gravy)	-0.760	-0.578	-0.716
Solubility	0.658302 (soluble)	0.553400 (soluble)	0.802264 (insoluble)
VaxiJen	-0.4924 (antigenic)	-0.4577 (antigenic)	-0.5928 (antigenic)

Table 4 Quality analysis of the three-dimensional structure model predicted, performed for the three chimeras

Program	rC1	rC2	rC3
QMEAN6 score	-13.41	-8.77	-17.31
C-score	-3.97	-0.31	-4.01
TM-score	0.29 ± 0.09	0.67 ± 0.13	0.29 ± 0.09
RMSD	16.4 ± 3.0	7.1 ± 4.1	16.6 ± 2.9

Conservation assessment

The chimera containing epitopes of GroEL, 17 kDa, and P26 proteins (rC1) has 33.78% similarity with the human HSPD1 60 kDa heat shock protein and 34.22% with the cat HSPD1 protein. When individually comparing each of the proteins that constitute the rC1 against the proteome of these two organisms, only the GroEL protein presents

identity, with a similarity of more than 50%, being these similarities again for the HSPD1 heat shock proteins from humans (ALQ33597.1) and cats (XP_019693975.1). These results were similar for the rC2 chimera containing epitopes of BadA, Pap31, and GroEL proteins since the similarity are only for the portion of the chimera referring

to the fragment of the GroEL protein. No significant similarity was found for the portions of the BadA and Pap31 proteins used in the construction of the chimera when evaluated individually. No significant similarity was found for the rC3 chimera that contained epitopes of OMP 89, OMP 43, and P26 proteins and for any of the proteins evaluated individually.

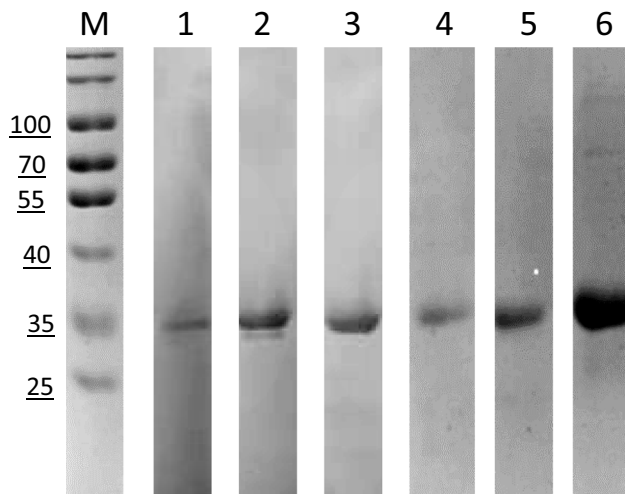

Fig. 2 WB using anti-histidine antibodies and serum from a patient naturally infected with *B. henselae* to evaluate the antigenicity of the three chimeric proteins. M: pre-stained protein ladder; 1 and 4: rC1 (37 kDa); 2 and 5: rC2 (35 kDa); and 3 and 6: rC3 (38 kDa). 1, 2, and 3: anti-histidine antibodies; 4, 5, and 6: patient serum

rC1, rC2, and rC3 proteins production and antigenicity

The three recombinant chimeras (rC1, rC2, and rC3) were efficiently expressed and purified using *E. coli* as a heterologous system. All proteins were expressed in insoluble form and recovered with a denaturing agent. WB assay using anti-histidine antibodies confirmed that the chimeric proteins present the expected mass of 37 kDa (rC1), 35 kDa (rC2), and 38 kDa (rC3) (Fig. 2). The antigenicity of the chimeric proteins was evaluated in a WB assay with the serum of a human naturally infected with *B. henselae*, demonstrating that the chimeras reacted with antibodies generated against native proteins (Fig. 2).

Anti-rC1, rC2, and rC3 antibodies response

Sera collected from animals on days 0, 14, 21, 28, 35, 42, 49, and 56 were evaluated in an ELISA assay using

Fig. 3 IgG antibody response in mouse immunized with recombinant chimeras (rC1, rC2, and rC3). IgG responses was determined by ELISA using the mouse serum 1:100 dilution and recombinant chimeras produced in *Escherichia coli* as antigen. Values are presented as means \pm SD. The significance was determined by the analysis of variance (Tukey's multiple comparison). Asterisk represent a difference compared to pre-immune serum (day 0). * $P < 0.05$. The samples were analyzed in triplicate

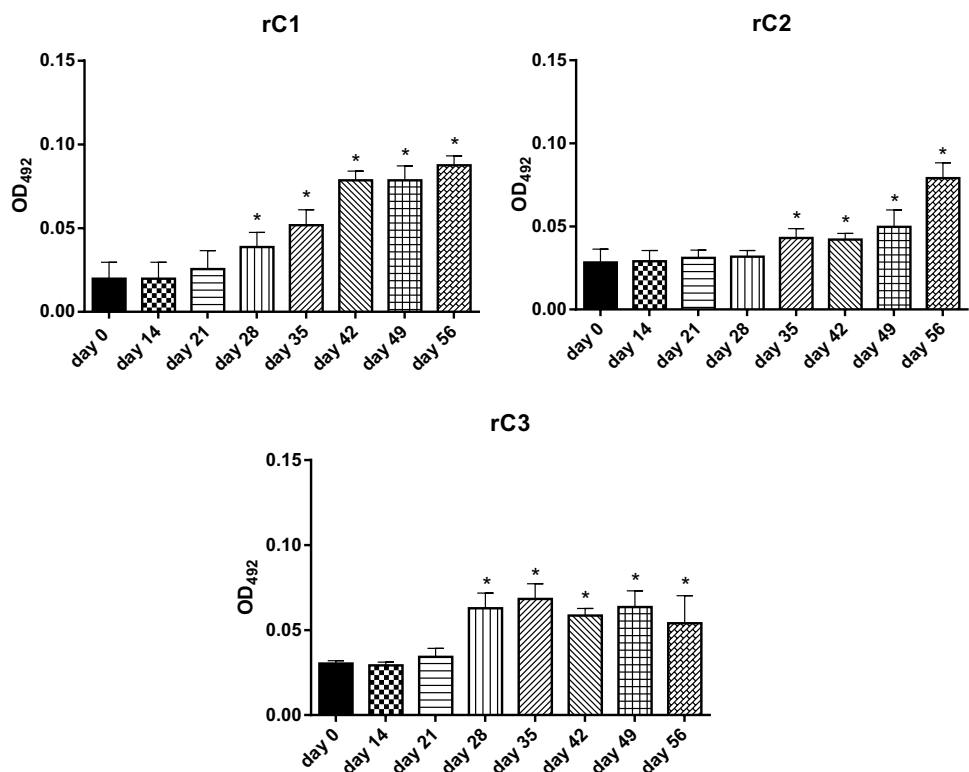

rC1, rC2, and rC3 as antigens, and the results are shown in Fig. 3. The animals immunized with the rC1 and rC3 showed a significant immune response from the 28th day ($P < 0.05$), and the animals immunized with the rC2 from the 35th day ($P < 0.05$). A significant IgG antibody response in animals remained until the 56th day of experimentation. Animals immunized with PBS + adjuvant did not show a significant immune response in this assay (data do not show). Animals immunized with seven doses (day 56) of rC1, rC2, and rC3 had a titer of 1:3200 ($P < 0.05$), 1:1600 ($P < 0.05$), and 1:1600 ($P < 0.05$), respectively, compared to pre-immune serum (day 0) (Fig. 4). Sera collected from immunized animals were evaluated for antibody isotypes generated during immunizations. For this purpose, a pool of immune sera collected on day 56 was used in an ELISA. A significant presence of IgA and IgG1 isotype was detected in animals immunized with rC1 and rC2 proteins, compared to the control group (PBS + adjuvant) (Fig. 5).

Antigenicity of chimeras

The antigenicity of the three chimeric proteins produced was evaluated by an ELISA assay, using 13 sera from naturally infected humans with *B. henselae*, confirmed

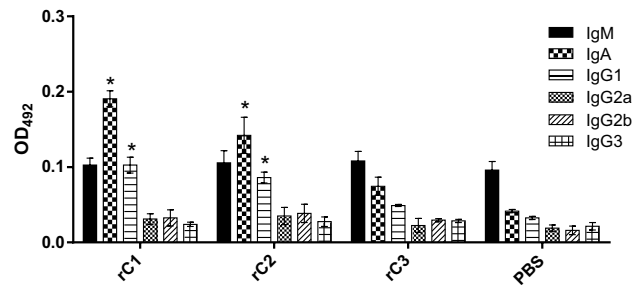

Fig. 5 Isotyping of anti-chimeras IgA, IgM, and IgG subclasses. The data represent the mean absorbances of mice pool sera collected at day 56. The results represent the mean absorbance ± SD of pooled serum samples assayed in triplicate in two independent experiments. The significance was determined by the analysis of variance (Tukey’s multiple comparison). Significant differences, in comparison to the control group (PBS), are shown by asterisks * $P < 0.05$

by the IFA technique, with different titers, and in the convalescent phase. The results are shown in Table 5. Of the 13 positive sera evaluated, 10 (76.9%) had a significant reaction ($P < 0.05$) with rC1, 11 (90.9%) with rC2, and 4 (30.8%) with rC3, when compared to the negative control. The antibodies present in the positive control sera showed a statistically different reaction from the negative control for the three chimeras.

Fig. 4 Titration curve of mice antiserum raised against recombinant chimeras (rC1, rC2, and rC3). The titer of the serum obtained from mice at day 56 was determined by measuring the binding of serial dilution of antiserum (1:100 to 1:1.6400) to plates coated with recombinant chimeras. Values are presented as means ± SD. The significance was determined by the analysis of variance (Tukey’s multiple comparison). Asterisk represent a difference compared to pre-immune serum (day 0). * $P < 0.05$. The samples were analyzed in triplicate

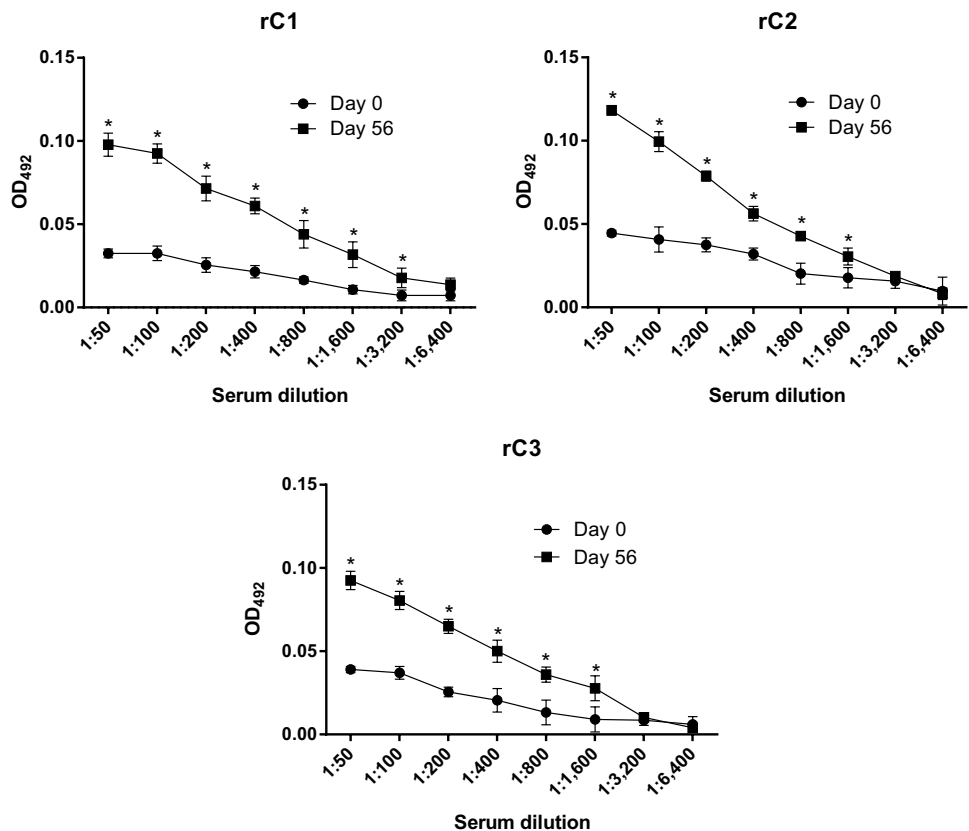

Table 5 Reaction of human sera positive for *B. henselae*, confirmed by the IFA technique, with the recombinant chimeras

Sera	rC1 [§]	rC2 [§]	rC3 [§]
1	0.336 ± 0.036*	0.255 ± 0.049*	0.257 ± 0.005*
2	0.073 ± 0.010	0.092 ± 0.013	0.116 ± 0.013
3	0.162 ± 0.035*	0.144 ± 0.001*	0.086 ± 0.013
4	0.285 ± 0.002*	0.153 ± 0.010*	0.189 ± 0.035*
5	0.260 ± 0.013*	0.245 ± 0.024*	0.261 ± 0.011*
6	0.168 ± 0.024*	0.168 ± 0.024*	0.130 ± 0.057*
7	0.148 ± 0.025*	0.153 ± 0.001*	0.110 ± 0.069
8	0.144 ± 0.008*	0.097 ± 0.054	0.103 ± 0.002
9	0.162 ± 0.027*	0.164 ± 0.006*	0.087 ± 0.016
10	0.188 ± 0.009*	0.179 ± 0.025*	0.120 ± 0.001
11	0.154 ± 0.006*	0.149 ± 0.013*	0.107 ± 0.003
12	0.104 ± 0.003	0.126 ± 0.004*	0.120 ± 0.014
13	0.115 ± 0.043	0.119 ± 0.004*	0.119 ± 0.062
Positive	0.347 ± 0.010*	0.218 ± 0.040*	0.216 ± 0.039*
Negative	0.039 ± 0.006	0.034 ± 0.006	0.042 ± 0.008

[§]Results represent the mean ± standard deviation (SD) of two independent experiments. *Significant differences compared to negative sera, * $P < 0.05$

Discussion

In this study, we reported the production of recombinant chimeric proteins containing epitopes of *B. henselae*. This was possible by using bioinformatics tools, widely used worldwide, which reduce time and costs in laboratory analysis. These tools are advantageous because conventional methods require the cultivation of pathogens to extract their antigenic proteins. Although some bacteria grow fast (*B. henselae* has fastidious growth), the large-scale extraction and testing of bacterial proteins are expensive and laborious (Tomar and De 2010).

Several proteins have been reported in the literature as *B. henselae* antigens, demonstrating a great possibility of research that can be done for the development of new diagnostic and vaccine inputs. We chose seven proteins (GroEL, 17 kDa, P26, BadA, Pap31, OMP 43, and OMP 89), whose antigenicity was proven in at least one study. In addition, some of the proteins used have great importance during *B. henselae* infection and are reported as important antigens. The GroEL family of proteins is considered one of the main antigens of pathogenic bacteria (Haake et al. 1997). The 17 kDa antigen can be expressed at considerable levels during *B. henselae* infection (Anderson et al. 1995). The P26 protein is the largest immunodominant antigen expressed in experimentally infected cats (Eberhardt et al. 2009), and OMP89 is one of the most immunogenic proteins of *B. henselae* (Chenoweth et al. 2004). In this context, GroEL, 17 kDa, P26, BadA, Pap31, OMP 43, and OMP 89 proteins are promising molecules for the development of new tools for the control of CSD.

Based on our similarity analysis, the sequence of the chimeras and the entire proteins used in their construction presented no significant similarity (0 to 34.22%) when compared to the hosts *Homo sapiens* (human) and *Felis catus* (cat) proteomes by BLAST. Based on the proposed criteria, these alignments are in the “twilight zone” of sequence alignment significance (Rost 1999). As an exception, when we evaluated the similarity of the entire GroEL protein, it showed 50% similarity with the HSPD1 heat shock protein of the two species evaluated. However, when composing the rC1 and rC2 chimeras, there was no significant similarity. Evaluation of the quality of protein structures is an important part of experimental structure validation, playing a valuable role in predicting protein structure. Because predicted models may contain substantial errors, reliable estimates of absolute quality are crucial to assess the suitability of a model for specific biotechnological applications (Benkert et al. 2011). In the quality analysis provided by the QMEAN6 program, which provides information on maintaining the native protein structure through positive scores, the scores obtained for chimeras 1, 2, and 3 were −13.1, −8.77, −17.31, respectively. These scores show that all chimeras obtained low scores (negative values), with rC2 being slightly better than the others. In the quality analysis of the models obtained for the three-dimensional structures predicted by the I-TASSER server (data not shown), performed by the QMEAN6 program, it was possible to observe the local error per residue, configuring potentially unreliable regions, which represents a low-quality indicator prediction of the three-dimensional position of these residues in the predicted model for the protein. In addition, the graphs for the Z-score for each component considered in the QMEAN6-score calculation revealed the predominance of red color, indicating a bad score for all proteins. Only rC2 had a slightly better score than the others. The TM-score, which assesses the structural similarity of proteins, had values of 0.29 (rC1 and rC3) and 0.13 (rC2), meaning less structural similarity, instead of models with correct topology. In addition, the score values obtained by the RMSD for rC1 and rC3 were 16, whereas that for rC2 was 7.1, meaning that rC2 has a greater structural similarity with the others.

RNA performs numerous cellular functions; thus, it becomes important to understand its structure to understand the mechanism of action. The secondary structure is the set of canonical base pairs, and the secondary structure can be accurately determined by comparative sequence analysis or can also be predicted (Reuter and Mathews 2010). The expression of high levels of recombinant proteins in *E. coli* is desired, and the stability of mRNA is crucial to this success. The secondary structure is a major factor in protein expression, and the results of mRNA prediction by the RNAfold server indicated that mRNA had sufficient stability

for effective translation. Greater stability consequently leads to a higher expression rate. Although the expression levels seem to be the same as seen in Fig. 2, in WB analysis, it is not possible to check the same efficiency.

Analysis of the physicochemical parameters by the ProtParam server indicated that rC1 and rC2 were soluble. However, they proved to be insoluble in vitro, which perhaps can be attributed to the wrong pH used in protein purification. The isoelectric points of rC1 and rC2 were 6.57 and 5.12, indicating that the proteins are acidic, and that of rC3 was 9.14, indicating that the protein is basic. The instability indices of the three proteins were 32.3, 34.3, and 23.67, indicating that the proteins were stable. The aliphatic indices of the three proteins were 80.27, 67.77, and 71.39: the greater the value, the higher protein thermostability. The GRAVY values of the three proteins were -0.76 , -0.57 , and -0.71 ; a value greater than zero indicates a hydrophobic protein.

In this study, the WB performed with the samples of humans naturally infected with *B. henselae* showed a reaction with the three recombinant chimeras. However, compared with rC2 and rC3, rC1 reacted weakly. In the ELISA assays using 13 different human sera positive for *B. henselae*, characterized by IFA, the rC2 ($n = 11$; 90.9%) protein reacted with most of them, followed by rC1 ($n = 10$; 76.9%) and rC3 ($n = 4$; 30.8%). The recognition of the recombinant chimeras by positive human sera evidenced that the constructions were able to maintain epitopes that are like the ones found on native GroEL, 17 kDa, P26, BadA, Pap31, OMP43, and OMP89 proteins. Thus, these results showed that the recombinant chimeras can be potentially used as antigens for the detection of specific antibodies of *B. henselae* in ELISA tests and/or in vaccine research against CSD. Additionally, the rC1, rC2, and rC3 induce a significant IgG antibody response in mice from the 28th day of immunization using Freund adjuvant, which remained until the 56th day of experimentation. A significant presence of IgA and IgG1 isotype was detected in animals immunized with rC1 and rC2 proteins.

Despite the importance of *B. henselae* as an emergent pathogen, prevention of the diseases caused by this agent in cats, dogs, and humans mostly rely on the use of ectoparasiticides that kill or inhibit the growth of cat fleas (André et al. 2022). There is no commercial vaccine to control CSD, and few experimental studies in this regard. GroEL, 17 kDa, P26, BadA, Pap31, OMP43, and OMP89 proteins are important antigens of *B. henselae* as described in the literature and should be tested for diagnostic and vaccine use. We reported for the first time the development of three chimeric proteins containing multi-epitopes of *B. henselae* obtained in a recombinant form. These recombinant chimeric antigens, built from in silico analysis, were recognized by antibodies generated during natural infection and can serve as biotechnological inputs for use in the diagnosis and control of CSD.

Acknowledgements The authors thank the Division of Dermatology, Department of Medicine of the State University of Campinas, Campinas, São Paulo, Brazil, for providing a serum sample.

Author contribution JMG and TLC – participated in the experiments and wrote the manuscript; SBF – participated in the experiments; ACPSN – supervised and participated in animal experiments; RW and LSP – performed the in silico analysis; ESL – characterized and provided the sera samples; DDH – coordinator, wrote and reviewed the manuscript.

Funding This work was financed in part by the Coordenação de Aperfeiçoamento de Pessoal de Nível Superior – Brasil (CAPES, <http://www.capes.gov.br/>)—Finance Code 001 and Conselho Nacional de Desenvolvimento Científico e Tecnológico (CNPq, <http://www.cnpq.br/>) which provided research and scholarship.

Data availability All relevant data have been included in the manuscript.

Code availability Not applicable.

Declarations

Ethics approval All animal procedures were performed at the animal facility of the Federal University of Pelotas (UFPEL) and approved by the Ethics Committee for Animal Experimentation (CEEA) of UFPEL. The CEEA at UFPEL is accredited by the Brazilian National Council for Animal Experimentation Control (CONCEA). The animal experiments were conducted under international guidelines.

Consent to participate All authors consented to participate in the research.

Consent for publication All authors read and approved the final manuscript and agreed to publish the research data.

Conflicts of interest DDH, JMG, and SBF are inventors of a patent protecting the recombinant chimeric proteins (*Instituto Nacional de Propriedade Industrial*—BR1020190275740).

References

- Anderson B, Lu E, Jones D, Regnery R (1995) Characterization of a 17-kilodalton antigen of *Bartonella henselae* reactive with sera from patients with cat scratch disease. *J Clin Microbiol* 33:2358–2365. <https://doi.org/10.1128/jcm.33.9.2358-2365.1995>
- André MR, Dumler JS, Herrera HM, Gonçalves LR, de Sousa KCM, Scorpio DG, de Santis ACGA, Domingos IH, de Macedo GC, Machado RZ (2016) Assessment of a quantitative 5' nuclease real-time polymerase chain reaction using the nicotinamide adenine dinucleotide dehydrogenase gamma subunit (nuoG) for *Bartonella* species in domiciled and stray cats in Brazil. *J Feline Med Surg* 18:783–790. <https://doi.org/10.1177/1098612X15593787>
- André MR, Neupane P, Lappin M, Herrin B, Smith V, Williams TI, Collins L, Bai H, Jorge GL, Balbuena TS, Bradley J, Maggi RG, Breitschwerdt EB (2022) Using proteomic approaches to unravel the response of *Ctenocephalides felis felis* to blood feeding and infection with *Bartonella henselae*. *Front Cell Infect Microbiol* 12:828082. <https://doi.org/10.3389/fcimb.2022.828082>

- Angkasekwinai N, Atkins EH, Romero S, Grieco J, Chao CC, Ching WM (2014) An evaluation study of Enzyme-Linked Immunosorbent Assay (ELISA) using recombinant protein Pap31 for detection of antibody against *Bartonella bacilliformis* infection among the Peruvian population. *Am J Trop Med Hyg* 90:690–696. <https://doi.org/10.4269/ajtmh.13-0131>
- Arnold K, Bordoli L, Kopp J, Schwede T (2006) The SWISS-MODEL workspace: a web-based environment for protein structure homology modelling. *Bioinformatics* 22:195–201. <https://doi.org/10.1093/bioinformatics/bti770>
- Benkert P, Biasini M, Schwede T (2011) Toward the estimation of the absolute quality of individual protein structure models. *Bioinformatics* 27:343–350. <https://doi.org/10.1093/bioinformatics/btq662>
- Bortoli CP, André MR, Seki MC, Pinto AA, Machado SDTZ, Machado RZ (2012) Detection of hemoplasma and *Bartonella* species and co-infection with retroviruses in cats subjected to a spaying/neutering program in Jaboticabal, SP, Brazil. *Rev Bras Parasitol Veterinária* 21:219–223. <https://doi.org/10.1590/s1984-29612012000300008>
- Breitschwerdt EB (2017) Bartonellosis, One Health and all creatures great and small. *Vet Dermatol* 28:96–e21. <https://doi.org/10.1111/vde.12413>
- Chenoweth MR, Greene CE, Krause DC, Gherardini FC (2004) Predominant outer membrane antigens of *Bartonella henselae*. *Infect Immun* 72:3097–3105. <https://doi.org/10.1128/IAI.72.6.3097-3105.2004>
- Costa F, Porter FH, Rodrigues G, Farias H, De Faria MT, Wunder EA, Osikowicz LM, Kosoy MY, Reis MG, Ko AI, Childs JE (2014) Infections by *Leptospira interrogans*, Seoul virus, and *Bartonella* spp. among norway rats (*Rattus norvegicus*) from the Urban slum environment in Brazil. *Vector-Borne Zoonotic Dis* 14:33–40. <https://doi.org/10.1089/vbz.2013.1378>
- Crissiuma A, Favacho A, Gershony L, Mendes-de-Almeida F, Gomes R, Mares-Guia A, Rozental E, Barreira J, Lemos E, Labarthe N (2011) Prevalence of *Bartonella* species DNA and antibodies in cats (*Felis catus*) submitted to a spay/neuter program in Rio de Janeiro, Brazil. *J Feline Med Surg* 13:149–151. <https://doi.org/10.1016/j.jfms.2010.08.010>
- Da Costa PSG, Brigatte ME, Greco DB (2005) Antibodies to *Rickettsia rickettsii*, *Rickettsia typhi*, *Coxiella burnetii*, *Bartonella henselae*, *Bartonella quintana* and *Eirlichia chaffeensis* among healthy population in Minas Gerais, Brazil. *Mem Inst Oswaldo Cruz* 100:853–859. <https://doi.org/10.1590/s0074-02762005000800006>
- da Silva BTG, de Souza AM, Campos SDE, de Lemos ERS, Favacho ARM, Almosny NRP (2018) Presence of *Bartonella* spp. in domestic cats from a state park in Rio de Janeiro, Brazil. *Rev Inst Med Trop Sao Paulo* 8:60–e14. <https://doi.org/10.1590/S1678-9946201860014>
- de Oliveira Braga MSC, de Paiva Diniz PPV, André MR, de Bortoli CP, Machado RZ (2012) Molecular characterisation of *Bartonella* species in cass from São Luís, state of Maranhão, north-eastern Brazil. *Mem Inst Oswaldo Cruz* 107:772–777. <https://doi.org/10.1590/S0074-02762012000600011>
- Doytchinova IA, Flower DR (2007) VaxiJen: A server for prediction of protective antigens, tumour antigens and subunit vaccines. *BMC Bioinformatics* 8:4. <https://doi.org/10.1186/1471-2105-8-4>
- Drummond MR, Lania BG, De Paiva Diniz PPV, Gilioli R, Demolin DMR, Scorpio DG, Breitschwerdt EB, Velho PENF (2018) Improvement of *Bartonella henselae* DNA detection in cat blood samples by combining molecular and culture methods. *J Clin Microbiol* 56:e01732–e1817. <https://doi.org/10.1128/JCM.01732-17>
- Eberhardt C, Engelmann S, Kusch H, Albrecht D, Hecker M, Autenrieth IB, Kempf VAJ (2009) Proteomic analysis of the bacterial pathogen *Bartonella henselae* and identification of immunogenic proteins for serodiagnosis. *Proteomics* 9:1967–1981. <https://doi.org/10.1002/pmic.200700670>
- Favacho AR, Roger I, Akemi AK, Pessoa JR AA, Varon AG, Gomes R, Godoy DT, Pereira S, Lemos ER (2014) Molecular identification of *Bartonella henselae* in a seronegative cat scratch disease patient with AIDS in Rio de Janeiro, Brazil. *Rev Inst Med Trop Sao Paulo* 56:363–5. <https://doi.org/10.1590/s0036-46652014000400017>
- Ferrara F, Di Niro R, D'Angelo S, Busetti M, Marzari R, Not T, Sblattero D (2014) Development of an enzyme-linked immunosorbent assay for *Bartonella henselae* infection detection. *Lett Appl Microbiol* 59:253–262. <https://doi.org/10.1111/lam.12286>
- Fontalvo MC, Favacho ARM, Araujo AC, dos Santos NM, de Oliveira GMB, Aguiar DM, de Lemos ERS, Horta MC (2017) *Bartonella* species pathogenic for humans infect pets, free-ranging wild mammals and their ectoparasites in the Caatinga biome, Northeastern Brazil: a serological and molecular study. *Brazilian J Infect Dis* 21:290–296. <https://doi.org/10.1016/j.bjid.2017.02.002>
- Gil H, Escudero R, Pons I, Rodríguez-Vargas M, García-Esteban C, Rodríguez-Moreno I, García-Amil C, Lobo B, Valcárcel F, Pérez A, Jiménez S, Jado I, Juste R, Segura F, Anda P (2013) Distribution of *Bartonella henselae* variants in patients, reservoir hosts and vectors in Spain. *PLoS ONE* 8:e68248. <https://doi.org/10.1371/journal.pone.0068248>
- Greene CE, Mcdermott M, Jameson PH, Atkins CL, Marks AM (1996) *Bartonella henselae* infection in cats: evaluation during primary infection, treatment, and rechallenge infection. *J Clin Microbiol* 34:1682–1685. <https://doi.org/10.1128/jcm.34.7.1682-1685.1996>
- Haake DA, Summers TA, McCoy AM, Schwartzman W (1997) Heat shock response and GroEL sequence of *Bartonella henselae* and *Bartonella quintana*. *Microbiology* 143:2807–2815. <https://doi.org/10.1099/00221287-143-8-2807>
- Hoey JG, Valois-Cruz F, Goldenberg H, Voskoboynik Y, Pffiffer J, Tilton RC, Mordechai E, Adelson ME (2009) Development of an immunoglobulin M capture-based enzyme-linked immunosorbent assay for diagnosis of acute infections with *Bartonella henselae*. *Clin Vaccine Immunol* 16:282–284. <https://doi.org/10.1128/CI.100305-08>
- Janson G, Zhang C, Prado MG, Paiardini A (2017) PyMod 2.0: improvements in protein sequence-structure analysis and homology modeling within PyMOL. *Bioinformatics* 33:444–446. <https://doi.org/10.1093/bioinformatics/btw638>
- Jost M, Latz A, Ballhorn W, Kempf VAJ (2018) Development of a specific and sensitive enzyme-linked immunosorbent assay as an *in vitro* diagnostic tool for detection of *Bartonella henselae* antibodies in human serum. *J Clin Microbiol* 56:e01329–e1418. <https://doi.org/10.1128/JCM.01329-18>
- Kitada AAB, Favacho ARM, Oliveira RVC, Pessoa AA, Gomes R, Honse CO, Gremião IDF, Lemos ERS, Pereira SA (2014) Detection of serum antibodies against *Bartonella* species in cats with sporotrichosis from Rio de Janeiro, Brazil. *J Feline Med Surg* 16:308–311. <https://doi.org/10.1177/1098612X13508193>
- Kordick DL, Breitschwerdt EB (1997) Relapsing bacteremia after blood transmission of *Bartonella henselae* to cats. *Am J Vet Res* 58:492–497
- Kwon HY, Im JH, Lee SM, Baek JH, Durey A, Park SG, Kang JS, Lee JS (2017) The seroprevalence of *Bartonella henselae* in healthy adults in Korea. *Korean J Intern Med* 32:530–535. <https://doi.org/10.3904/kjim.2016.010>
- Lamas CC, Ramos RG, Lopes GQ, Santos MS, Golebiovski WF, Weksler C, Ferraiuoli GIDA, Fournier PE, Lepidi H, Raoult D (2013) *Bartonella* and *Coxiella* infective endocarditis in Brazil: Molecular evidence from excised valves from a cardiac surgery referral center in Rio de Janeiro, Brazil, 1998 to 2009. *Int J Infect Dis* 17:e65–6. <https://doi.org/10.1016/j.ijid.2012.10.009>
- Li DM, Liu QY, Zhao F, Hu Y, Xiao D, Gu YX, Song XP, Zhang JZ (2011) Proteomic and bioinformatic analysis of outer membrane proteins of the protobacterium *Bartonella henselae* (Bartonellaceae). *Genet Mol Res* 10:1789–1818. <https://doi.org/10.4238/vol10-3gm1153>

- Loa CC, Mordechai E, Tilton RC, Adelson ME (2006) Production of recombinant *Bartonella henselae* 17-kDa protein for antibody-capture enzyme-linked immunosorbent assay. *Diagn Microbiol Infect Dis* 55:1–7. <https://doi.org/10.1016/j.diagmicrobio.2005.10.020>
- Magnan CN, Randall A, Baldi P (2009) SOLpro: Accurate sequence-based prediction of protein solubility. *Bioinformatics* 25:2200–2207. <https://doi.org/10.1093/bioinformatics/btp386>
- Malheiros J, Costa MM, do Amaral RB, de Sousa KCM, André MR, Machado RZ, Vieira MIB (2016) Identification of vector-borne pathogens in dogs and cats from Southern Brazil. *Ticks Tick Borne Dis* 7:893–900. <https://doi.org/10.1016/j.tbd.2016.04.007>
- McCool TL, Hoey JG, Montileone F, Goldenberg HB, Mordechai E, Adelson ME (2008) Discovery and analysis of *Bartonella henselae* antigens for use in clinical serologic assays. *Diagn Microbiol Infect Dis* 60:17–23. <https://doi.org/10.1016/j.diagmicrobio.2007.07.017>
- Miceli NG, Gavioli FA, Gonçalves LR, André MR, Sousa VRF, de Sousa KCM, Machado RZ (2013) Molecular detection of feline arthropod-borne pathogens in cats in Cuiabá, state of Mato Grosso, central-western region of Brazil. *Rev Bras Parasitol Vet* 22:385–390. <https://doi.org/10.1590/s1984-29612013000300011>
- Pennisi MG, Marsilio F, Hartmann K, Lloret A, Addie D, Belák S, Boucraut-Baralon C, Egberink H, Frymus T, Gruffydd-Jones T, Hosie MJ, Lutz H, Möstl K, Radford AD, Thiry E, Truyen U, Horzinek MC (2013) *Bartonella* species infection in cats: ABCD guidelines on prevention and management. *J Feline Med Surg* 15:563–569. <https://doi.org/10.1177/1098612X13489214>
- Pitassi LHU, de Paiva Diniz PPV, Scorpio DG, Drummond MR, Lania BG, Barjas-Castro ML, Gilioli R, Colombo S, Sowly S, Breitschwerdt EB, Nicholson WL, Velho PENF (2015) *Bartonella* spp. bacteremia in blood donors from Campinas, Brazil. *PLoS Negl Trop Dis* 9:e0003467. <https://doi.org/10.1371/journal.pntd.0003467>
- Regier Y, Órourke F, Kempf VAJ (2016) *Bartonella* spp. - A chance to establish One Health concepts in veterinary and human medicine. *Parasites and Vectors* 9:261. <https://doi.org/10.1186/s13071-016-1546-x>
- Regnery RL, Rooney JA, Johnson AM, Nesby SL, Manzewitsch P, Beaver K, Olson JG (1996) Experimentally induced *Bartonella henselae* infections followed by challenge exposure and antimicrobial therapy in cats. *Am J Vet Res* 57:1714–1719
- Reuter JS, Mathews DH (2010) RNAstructure: Software for RNA secondary structure prediction and analysis. *BMC Bioinformatics* 11:129. <https://doi.org/10.1186/1471-2105-11-129>
- Rost B (1999) Twilight zone of protein sequence alignments. *Protein Eng* 12:85–94. <https://doi.org/10.1093/protein/12.2.85>
- Staggemeier R, Pilger DA, Spilki FR, Cantarelli VV (2014) Multiplex Sybr® Green-real time PCR (qPCR) assay for the detection and differentiation of *Bartonella henselae* and *Bartonella clarridgeiae* in cats. *Rev Inst Med Trop Sao Paulo* 56:93–95. <https://doi.org/10.1590/s0036-46652014000200001>
- Tomar N, De RK (2010) Immunoinformatics: an integrated scenario. *Immunology* 131:153–168. <https://doi.org/10.1111/j.1365-2567.2010.03330.x>
- Vieira-Damiani G, De Paiva Diniz PPV, Urso Pitassi LH, Sowly S, Scorpio DG, Lania BG, Drummond MR, Benetti Soares TC, Barjas-Castro ML, Breitschwerdt EB, Nicholson WL, Ferreira Velho PEN (2015) *Bartonella clarridgeiae* bacteremia detected in an asymptomatic blood donor. *J Clin Microbiol* 53:352–356. <https://doi.org/10.1128/JCM.00934-14>
- Wagner CL, Riess T, Linke D, Eberhardt C, Schäfer A, Reutter S, Maggi RG, Kempf VAJ (2008) Use of *Bartonella* adhesin A (BadA) immunoblotting in the serodiagnosis of *Bartonella henselae* infections. *Int J Med Microbiol* 298:579–590. <https://doi.org/10.1016/j.ijmm.2008.01.013>
- Werner JA, Feng S, Chomel BB, Hodzic E, Kasten RW, Barthold SW (2008) P26-based serodiagnosis for *Bartonella* spp. infection in cats. *Comp Med* 58:375–380
- Yang J, Yan R, Roy A, Xu D, Poisson J, Zhang Y (2014) The I-TASSER suite: protein structure and function prediction. *Nat Methods* 12:7–8. <https://doi.org/10.1038/nmeth.3213>

Publisher's note Springer Nature remains neutral with regard to jurisdictional claims in published maps and institutional affiliations.

Springer Nature or its licensor (e.g. a society or other partner) holds exclusive rights to this article under a publishing agreement with the author(s) or other rightsholder(s); author self-archiving of the accepted manuscript version of this article is solely governed by the terms of such publishing agreement and applicable law.

Authors and Affiliations

Jênifer Malheiros Gonçalves^{1,2} · Thayná Laner Cardoso¹ · Stella Buchhorn de Freitas^{1,2} · Rafael Woloski² · Amilton Clair Pinto Seixas Neto¹ · Luciano da Silva Pinto² · Elba Sampaio de Lemos³ · Daiane Drawanz Hartwig^{1,2,4} 

¹ Laboratório de Bacteriologia E Bioensaios (LaBBio), Departamento de Microbiologia E Parasitologia, Instituto de Biologia, Universidade Federal de Pelotas, Capão Do Leão, Rio Grande Do Sul, Brazil

² Núcleo de Biotecnologia, Centro de Desenvolvimento Tecnológico (CDTec), Universidade Federal Pelotas, Capão Do Leão, Rio Grande Do Sul, Brazil

³ Laboratório de Hantavírus E Rickettsioses (LHR), Fundação Oswaldo Cruz (FIOCRUZ), Rio de Janeiro, RJ, Brazil

⁴ Biology Institute, Federal University of Pelotas, Pelotas, RS CEP 96010–900, Brazil