



# Effects of antiretroviral treatment and nadir CD4 count in progression to cardiovascular events and related comorbidities in a HIV Brazilian cohort: a multi-stage approach

Raquel de Vasconcellos Carvalhaes de Oliveira, Silvia Emiko Shimakura, Dayse Pereira Campos, Yara Hahr Marques Hökerberg, Flaviana Pavan Victoriano, Sayonara Ribeiro, Valdiléa G. Veloso, Beatriz Grinsztejn & Marília Sá Carvalho

To cite this article: Raquel de Vasconcellos Carvalhaes de Oliveira, Silvia Emiko Shimakura, Dayse Pereira Campos, Yara Hahr Marques Hökerberg, Flaviana Pavan Victoriano, Sayonara Ribeiro, Valdiléa G. Veloso, Beatriz Grinsztejn & Marília Sá Carvalho (2017): Effects of antiretroviral treatment and nadir CD4 count in progression to cardiovascular events and related comorbidities in a HIV Brazilian cohort: a multi-stage approach, *AIDS Care*, DOI: [10.1080/09540121.2017.1391984](https://doi.org/10.1080/09540121.2017.1391984)

To link to this article: <https://doi.org/10.1080/09540121.2017.1391984>



Published online: 23 Oct 2017.



Submit your article to this journal [↗](#)



Article views: 49









View related articles [↗](#)



View Crossmark data [↗](#)



## Effects of antiretroviral treatment and nadir CD4 count in progression to cardiovascular events and related comorbidities in a HIV Brazilian cohort: a multi-stage approach

Raquel de Vasconcellos Carvalhaes de Oliveira <sup>a</sup>, Sílvia Emiko Shimakura <sup>b</sup>, Dayse Pereira Campos<sup>a</sup>, Yara Hahr Marques Hökerberg<sup>a</sup>, Flaviana Pavan Victoriano <sup>a</sup>, Sayonara Ribeiro <sup>a</sup>, Valdiléa G. Veloso<sup>a</sup>, Beatriz Grinsztejn <sup>a</sup> and Marília Sá Carvalho <sup>c</sup>

<sup>a</sup>Instituto Nacional de Infectologia Evandro Chagas, Fundação Oswaldo Cruz, Rio de Janeiro, Brazil; <sup>b</sup>Setor de Ciências Exatas, Universidade Federal do Paraná, Curitiba, Brazil; <sup>c</sup>Programa de Computação Científica, Fundação Oswaldo Cruz, Rio de Janeiro, Brazil

### ABSTRACT

The use of highly active antiretroviral therapy has resulted in changes of comorbidity profile in people living with HIV (PLHIV), increasing non-AIDS-related events. The occurrence of cardiovascular events is greater in PLHIV, but the mechanism responsible for it is still controversial. This article aimed to investigate factors associated with the progression to cardiovascular events in PLHIV using HAART. A 15-years cohort study with 1135 PLHIV was conducted in Rio de Janeiro-Brazil. Clinical progression was stratified in five states: No comorbidities ( $s_1$ ), arterial hypertension ( $s_2$ ), lipid abnormalities ( $s_3$ ), hypertension and lipid abnormalities ( $s_4$ ) and major cardiovascular events (stroke, coronary artery disease, thrombosis or death) ( $s_5$ ). Semi-Markov models evaluated the effects of cardiovascular traditional factors, treatment and clinical covariates on transitions between these states. Hazard Ratios (HR) and 95% confidence intervals (CI) were provided. In addition to traditional factors (age, sex, educational level and skin color), the development of one comorbidity (lipid abnormalities or hypertension) increased in patients with low nadir CD4 ( $<50$  cells/mm<sup>3</sup>), (HR = 1.59, CI 1.11–2.28 and 1.36, CI 1.11–1.66, respectively). The risk to experience a second comorbidity ( $s_3 \rightarrow s_4$ ) increased 75% with low nadir CD4. Age was the only factor that increased the risk of major cardiovascular events once having lipid abnormalities with or without hypertension ( $s_3, s_4 \rightarrow s_5$ ). The prolonged use of certain antiretroviral drugs (abacavir, didanosine, ritonavir, lopinavir, amprenavir and fosamprenavir) increased the risk of direct transition ( $s_1 \rightarrow s_5$ ) to major cardiovascular events (HR = 5.29, CI 1.16–24.05). This analysis suggests that prolonged use of certain antiretroviral drugs led directly to major cardiovascular events, while low nadir CD4 only affected the occurrence of lipid abnormalities and hypertension. Management strategies, including rational use of complex exams (such as, computed-tomography angiography), statins and antihypertensives, should be developed based on the distinct roles of antiretroviral use and of HIV infection itself on the progression to cardiovascular events.

### ARTICLE HISTORY

Received 3 March 2017  
Accepted 10 October 2017

### KEYWORDS

Cardiovascular events; progression; HIV/AIDS; multi-stage model; cohort study

## Introduction

The use of highly active antiretroviral therapy (HAART) resulted in a significant reduction in morbidity and mortality of HIV infection, and improved quality of life for people living with HIV (PLHIV). In this context, the incidence of HIV-related events decreased with an increasing incidence of HIV non-related events, including cardiovascular diseases. Although these diseases are expected due to the extended survival, there is evidence that their incidences and mortality rates are higher than in the general population (Feinstein et al., 2016).

This may be due directly to HIV infection, and in part boosted by a longer exposure to drug therapy and its

possible adverse effects, such as lipid abnormalities and hypertension. The mechanism by which HIV infection induces CVD, lipid abnormalities, lipodystrophy and thrombosis is still controversial in the literature. The more accepted assumption is that the process of HIV infection accelerates atherosclerosis through the effect on cholesterol transport, infection of endothelial cells or cardiac myocytes (Arildsen, Sørensen, Ingerslev, Østergaard, & Laursen, 2013; Martin-Iguacel, Llibre, & Friis-Moller, 2015; Triant, 2012).

Some antiretroviral drugs might be involved in the mechanism of CVDs in PLHIV, especially for those using protease inhibitors (PI). They would be prone to

develop lipid disorders, coronary artery disease (CVDs), stroke, and thrombosis (Gomo et al., 2014; Islam, Wu, Jansson, & Wilson, 2012; Reyskens & Faadiel Essop, 2014). One rationale was that some PI drugs (indinavir, lopinavir/ritonavir, saquinavir) activate the formation of adipocytes by the renin-angiotensin system, in addition to cause oxidative stress and the increase of ubiquitin-protein within cells, leading to insulin resistance, lipodystrophy, hypertension and cardiovascular events (Reyskens & Faadiel Essop, 2014). Subsequently, studies with higher numbers of individuals demonstrated that other drug classes, such as nucleoside and non-nucleoside reverse transcriptase inhibitors (NRTI and NNRTI), also lead to atherosclerosis through lipid imbalance and platelet activation (D:A:D Study Group, 2008; Islam et al., 2012; Martin-Iguacel et al., 2015; Trevillyan et al., 2015).

At the same time, the SMART clinical trial showed a significant increase in major cardiovascular events in individuals using intermittent HAART with CD4 < 250 cells, compared to those on continued therapy, suggesting that the infection itself increases the risk of metabolic changes (e.g., decreased HDL cholesterol) and cardiovascular events (The SMART Study Group, 2006). Although not showing difference per cardiovascular events, a study reported that patients with immediate initiation of HAART presented less HIV non-related events (The INSIGHT START Study Group, 2015). Moreover, Zanni et al. (2014) have found coronary plaques by computed-tomography angiography in PLHIV without signs of CVD or lipid-lowering treatment.

Multi-state, Markovian and semi-Markovian models are adequate to evaluate the progression of chronic diseases. However, most studies on AIDS focused on the progression of immune or virological status, (Foucher, Mathieu, Saint-Pierre, Durand, & Daurès, 2005; Kousignian et al., 2003; Lawless & Rad, 2015; Mathieu, Foucher, Dellamonica, & Daures, 2007; Oliveira et al., 2013) and we did not find any study focusing on the comorbidities prior to the onset of CVD (e.g., dyslipidemia/hypertension). Multi-state models may be useful in estimating different risk factors associated with progression to CVD (from a mild status, without comorbidities, passing through intermediate statuses with comorbidities to more serious conditions, with a cardiovascular event), since it allows each individual to be observed in a chain of multiple events.

In Brazil, there is a pioneer public program to promote universal access to HAART for PLHIV since 1996. Therefore, since the benefit of HAART drugs are unquestionable for HIV treatment, we intend to investigate the role of a poor immune recovery based on nadir CD4 count and ARV classes to progression to major

cardiovascular events or related deaths in people living with HIV.

## Methods

### Setting

A large cohort of PLHIV have been treated since 1986 at the Evandro Chagas National Institute of Infectious Diseases – INI/FIOCRUZ, a research center in Rio de Janeiro, Brazil. Most of them were referred after their first positive ELISA in other public health units to participate in clinical trials.

This study is a retrospective cohort of PLHIV older than or equal to 18 years with at least one prescription of highly active antiretroviral therapy (HAART). PLHIV eligible for this study were those naive to antiretroviral therapy with a follow-up of at least 60 days between January 1, 1996 and December 31, 2010. We excluded individuals with previous diagnosis, clinical signs, or laboratory tests at entry, such as: hypertension, dyslipidemia, lipodystrophy, thrombosis, coronary artery disease (CVD), and stroke. Health professionals supervised by a specialized physician collected data from medical records on a standardized form (Campos et al., 2005).

This study was approved by the INI/Fiocruz Research Ethics Committee.

### Outcome

Five states were determined to investigate the risk factors for the progression to CVD or death, based on historical conditions related to the development of cardiovascular events: No CVD-related comorbidities (thereafter, “No comorbidities”)- lipid abnormalities and arterial hypertension ( $s_1$ ), arterial hypertension ( $s_2$ ), lipid abnormalities ( $s_3$ ), hypertension + lipid abnormalities ( $s_4$ ), and major cardiovascular events ( $s_5$ ) – stroke, coronary artery disease, thrombosis or death non related to HIV (Figure 1). The “No comorbidities” state was defined at the study entry, i.e., in the first HIV+ test result or at the first visit to INI, whichever came first. Although some conditions may be temporary (e.g., hyperlipidemia), a reversion to the state “No comorbidities” was not considered. Major cardiovascular events and death not related to HIV could only be evaluated all together due to the small number of specific conditions. Censoring was defined by the last date of medical visit or the date of death from causes directly related to immunodeficiency or from external causes.

Diagnosis of hypertension, dyslipidemia, lipodystrophy, stroke, CVD, and arterial thrombosis, performed

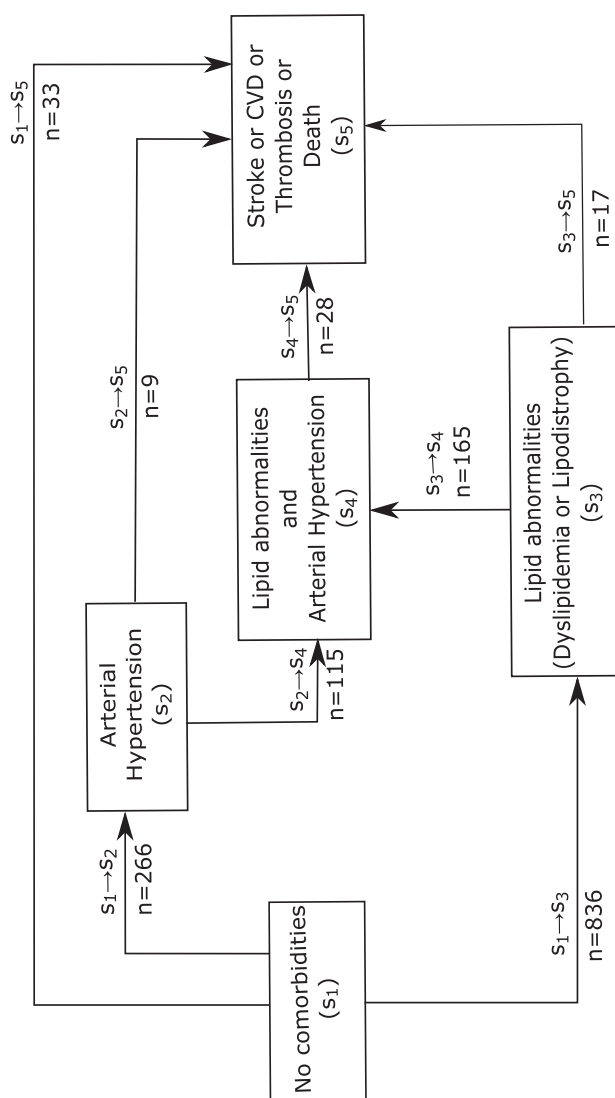

**Figure 1.** Progression according to lipid abnormalities, major cardiovascular diseases, and death in 1135 people living with HIV, Rio de Janeiro, 1996–2010.

Notes:  $s_1$  = No Comorbidities,  $s_2$  = Hypertension,  $s_3$  = Lipid Abnormalities (Dyslipidemia or Lipodystrophy),  $s_4 = s_2 + s_3$ ,  $s_5$  = CVD or stroke or thrombosis or death.

at INI or prior to the initiation of follow-up, were classified in accordance to the International Classification of Diseases 10th revision (ICD-10). Dyslipidemia (E78) was defined by: LDL > 159 mg/dl, HDL < 40 mg/dl, total cholesterol > 239 mg/dl or triglycerides > 199 mg/dl. Lipodystrophy (E88.1) was clinically defined by the disappearance of subcutaneous adipose tissue, and arterial hypertension as (WHO, 2003). The CVD occurred due to the following events: stable angina, unstable angina, and myocardial infarction (I77.9). Stroke (I64) was defined as the occurrence of at least one ischemic episode and arterial thrombosis as an ischemic disease of the lower limbs (I82.9). Trained physicians revised all causes of death.

The sojourn time (time spent in each state) was calculated as the number of days until the next state or censoring. Explanatory variables.

The following explanatory variables were analyzed: sex, age, skin color, education, nadir CD4 count prior to treatment initiation as a proxy of poor immune recovery (Negredo et al., 2010), use of prophylaxis for opportunistic infections, participation in clinical trials, use of ARV related to CVD (lipid abnormalities, diastolic hypertension and major CVD events), hospitalization, type of exposure (sexual and non-sexual), death, and cause of death (related or non-related to HIV infection).

The nadir CD4 count was obtained as the lowest CD4 count measurement prior to the initiation of the antiretroviral (ARV) therapy. In 166 individuals who had CD4 counts only after the initiation of HAART, CD4 nadir was ascribed to the first CD4 count available within 180 days of treatment initiation. Two cutoffs were used 50 and 200 cells/mm<sup>3</sup>, the latter considered the threshold for starting HAART and for monitoring opportunistic diseases between 1996 and 2010 (WHO, 2006).

During the follow-up 30 ARVs of several classes were used according to the Brazilian Guidelines for HIV/AIDS treatment: Protease Inhibitor (PI), Nucleoside Reverse Transcriptase Inhibitor (NRTI), Non-Nucleoside Reverse Transcriptase Inhibitor (NNRTI), Fusion inhibitor, and CCR5 inhibitor. There were different ARV regimens prescribed per the availability and changes in recommendations of the Brazilian guidelines for HIV treatment (Ministério da Saúde, 2008). Most patients started HAART with the following ARV: NRTI (Zidovudine, Lamivudine, Tenofovir), NNRTI (Efavirenz and Nevirapine) and PI (Atazanavir, Lopinavir + Ritonavir and Ritonavir Boosted). The two HAART regimens more frequently prescribed were Zidovudine + Lamivudine + Efavirenz and Lamivudine + Efavirenz + Tenofovir (33,84% and 5,81%, respectively).

Use of ARVs related to CVD was defined by a cumulative use >6 months of at least one of the six ARVs as per prescriptions dispensed by the pharmacy: abacavir, didanosine, ritonavir, lopinavir, amprenavir, and fosamprenavir, all showing indicators of cardiovascular effects according to the literature (D:A:D Study Group, 2008; Islam et al., 2012; Martin-Iguacel et al., 2015). The use of ARVs related to CVD was estimated for each state transition, considering previous times of use of these six ARVs.

The use of prophylaxis for opportunistic infections (such as Pneumocystosis, Tuberculosis and Toxoplasmosis) was considered when applied at least one time. Hospitalization was considered when it occurred at least once during the study period, regardless of the cause for admission. Participation in clinical trials was

considered when present after the entry date. Sociodemographic variables (such as sex, age, skin color, education) and nadir CD4 were obtained at the baseline (inclusion date), and others were considered time-dependent variables.

### Semi-Markov model

The progressive model proposed here allows us to study the evolution of some comorbidities up to the occurrence of cardiovascular events or death, using extensions of Cox semi-parametric model, which allows for risk interpretation as a Hazard Ratio (HR). This is a multi-state model that estimates the transition intensities between states based only on the current state (Andersen, 2002; Huzurbazar, 2005; Titman & Sharples, 2010), and the sojourn time in each state (Foucher et al., 2005), named Semi-Markov model.

Firstly, single covariate multi-state models were used for each explanatory variable, and then a multi-covariate multi-state model was adjusted based on the theoretical relevance of the nine explanatory variables selected, irrespective of statistical significance. Participation in clinical trials, hospitalization and use of prophylaxis were maintained in the multi-covariate model as control variables. Age was treated as a continuous variable based on exploratory analysis for penalized splines of eight transition intensities and the ANOVA test ( $p = 0.2494$ ). Confidence intervals at 95% were provided for Adjusted and Crude HR. The quality of the model adjustment was satisfactory regarding proportionality by Schoenfeld residuals, and we found few outliers by the deviance residuals (data not shown).

Cases with missing data at least one variable were excluded in the analysis. The analysis was performed in mstate library of the R statistical package, version 3.23 (R Core Team, 2015; Wreede, Fiocco, & Putter, 2011).

## Results

### Participant characteristics

From 1391 PLHIV met the inclusion criteria, 1135 individuals were included in the analysis (Figure 2).

From the 1135 PLHIV included, the majority was men (65.5%), white (57.3%), had low educational level (53.5%), with sexual exposure (83.1%). Median age was 34.7 years, ranging from 18.0–74.6 years. During follow-up (mean = 2902 days, 64–9314 days), 38.1% reported hospitalization and 40.0% had participated in clinical trials. The maximum number of state transitions per individual was 3. Table 1 shows the descriptive analysis according to the order of the transition in the individual.

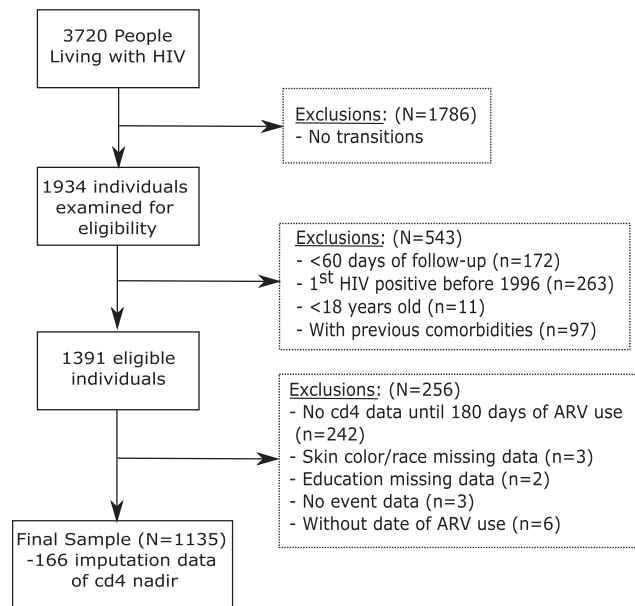

**Figure 2.** Flow chart of people living with HIV who met inclusion/exclusion criteria, Rio de Janeiro, 1996–2010.

Most transitions ( $n=1102$ , 75.0%) were from the no comorbidities state ( $s_1$ ) to states with abnormal laboratory/clinical signs (hypertension –  $s_2$ , Lipid Abnormalities –  $s_3$ , and hypertension and lipid abnormalities –  $s_4$ ), see Figure 1. Among the 87 transitions to a more serious state (major cardiovascular events-  $s_5$ ), 16 were manifestations of CVD, 23 of stroke, 3 of thrombosis, 1 CVD with subsequent stroke, and 44 were deaths non-related to HIV. Many deaths occurred after passing through states with abnormal laboratory results/clinical signs ( $n=25$ ; 56.8%).

### Predictors of progression to CVD

Incidence rates of some transitions states for the variables sex, age, race/skin color, education, nadir CD4 count and use of ARVs related to CVD remain statistically significant and with similar effect in single and multi-covariate, multi-state models (Tables 2 and 3).

As for the multi-covariate, multi-state model, men had a 25% lower risk to transition from  $s_1$  to  $s_2$ ; but with a 30% increased risk of transition to state  $s_3$ . Age showed a linear increase of risk for transitions  $s_1 \rightarrow s_2$ ,  $s_1 \rightarrow s_3$ ,  $s_3 \rightarrow s_4$ ,  $s_3 \rightarrow s_5$ , and  $s_4 \rightarrow s_5$ . A one-year increase in use of HAART raised risks to 6% and 2% for  $s_1 \rightarrow s_2$  and  $s_1 \rightarrow s_3$  transitions, respectively. The risk of transition from state  $s_3$  to the states  $s_4$  and  $s_5$  is higher for older patients (HR = 1.03 and 1.08, respectively). Age also increased the risk of transition from state  $s_4$  to the



**Table 1.** Descriptive analysis of the transitions regarding progression to cardiovascular events (CVD) in 1135 HIV+ individuals at Rio de Janeiro, Brazil, 1996–2010.

Variables	Categories	1st Transition (N = 1135) n(%)	2nd Transition (N = 306) n(%)	3rd Transition (N = 28) n(%)
Sex	Male	743(65.5)	186(60.8)	17(60.7)
	Female	392(34.5)	120(39.2)	11(39.3)
Age (years)	Median (Interquartile Range)	34.7(28.4–41.8)	37.5(30.2–44.2)	41.9(39.1–47.8)
Skin color	White	650(57.3)	177(57.8)	17(60.7)
	Non-White	485(42.7)	129(42.2)	11(39.3)
Education	Less than High School	607(53.5)	165(53.9)	17(60.7)
	High School or more	528(46.5)	141(46.1)	11(39.3)
Category of exposure	Sexual	943(83.1)	254(83.0)	24(85.7)
	Non-sexual	37(3.3)	9(2.9)	1(3.6)
	Missing	155(13.7)	43(14.1)	3(10.7)
Use of ARVs related to CVD >180 days	No	1124(99.0)	241(78.8)	21(75.0)
	Yes	11(1.0)	65(21.2)	7(25.0)
CD4 nadir (cells/mm <sup>3</sup> )	<50	214(18.9)	64(20.9)	4 (14.3)
	50–200	362(31.9)	92(30.1)	8(28.6)
	>200	559(49.3)	150(49.0)	16(57.1)
Prophylaxis for opportunistic infections	Yes	41(3.6)	106(34.6)	9(32.1)
	No	1094(96.4)	200(65.4)	19(67.9)
Clinical Trial	Yes	454(40.0)	118(38.6)	8(28.6)
	No	681(60.0)	188(61.4)	20(71.4)
Death	Yes	125(11.0)	38(12.4)	13(46.4)
	No /Missing	1010(89.0)	268(87.6)	15(53.6)
Cause of Death	HIV Not-Related	18(1.6)	14(4.6)	9(32.1)
	Undetermined	28(2.5)	12(3.9)	4(14.3)
	HIV Related	77(6.8)	12(3.9)	–
	External Causes	2 (0.2)	–	–
	Not Applicable	1010(89.0)	268(87.6)	15(53.6)
Hospitalization during study	No	702(61.9)	173(56.5)	10(35.7)
	Yes	433(38.1)	133(43.5)	18(64.3)
Initial Event	No comorbidities ( $s_1$ )	1135(100.0)	–	–
	Hypertension ( $s_2$ )	–	124(40.5)	–
	Lipid Abnormalities( $s_3$ )	–	182(59.5)	–
	Hypertension + Lipid Abnormalities ( $s_2+s_3$ )	–	–	28(100.0)
	–	–	–	–

most serious state ( $s_5$ ) to 7% per one-year increase (Table 3).

Non-white subjects had a risk 16% higher in the transition  $s_1 \rightarrow s_3$ . Those with at least elementary education had lower transition risk  $s_1 \rightarrow s_2$  and  $s_1 \rightarrow s_5$  than those with lower education (HR = 0.74 and 0.37, respectively). Nadir CD4 below 50 cells/mm<sup>3</sup> increased the risk by 59% and 36%, respectively, in transitions  $s_1 \rightarrow s_2$  and  $s_1 \rightarrow s_3$ , and by 75% in the transition  $s_3 \rightarrow s_4$ , when compared to individuals with cells count between 50 and 200 cells/mm<sup>3</sup>. Subjects using any ARV related to CVD for more than six months (abacavir, didanosine, ritonavir, lopinavir, amprenavir, fosamprenavir), increased the risk (HR = 5.29) of moving from no comorbidities state ( $s_1$ ) straight to a more serious state ( $s_5$ ) (Table 3).

## Discussion

This study showed that the clinical evolution of people living with HIV should not be limited to traditional risk factors to develop major cardiovascular events. Despite our assumption that management and treatment of PLHIV firstly contributes to the occurrence of CVD-

related comorbidities, we observe that these factors differently affect the progression to major cardiovascular events. Our results suggest that the role of HIV infection is restricted to the development of lipid abnormalities and hypertension, while the prolonged use of certain ARVs leads to major cardiovascular events in individuals without previous signs of lipid abnormalities or arterial hypertension.

The incidence of complications in PLHIV in our cohort, such as stroke, CVD or death was 4.2% and the age median was 37.7 years, a figure close to that found by Triant *et al.* to myocardial infarction (4.9% and 38 years) (Triant, Lee, Hadigan, & Grinspoon, 2007). Previous studies showed the importance of investigating CVD and other diseases in PLHIV, since they have higher incidence of CVD and other HIV non-related diseases than the general population (Feinstein *et al.*, 2016; Islam *et al.*, 2012; Martin-Iguacel *et al.*, 2015; Paisible *et al.*, 2015; Triant *et al.*, 2007). Most guidelines to manage patients with high level of CVD risk and cholesterol do not mention the particularities of PLHIV, despite the higher incidence of cardiovascular events in PLHIV and the interaction between statins and ARVs (Josephson, 2010).

**Table 2.** Single-covariate Semi-Markov model to major cardiovascular events progression in 1135 HIV+ individuals. Rio de Janeiro, Brazil, 1996–2010.

Variables	Categories	Crude HR (IC95%)							
		$s_1 \rightarrow s_2$	$s_1 \rightarrow s_3$	$s_1 \rightarrow s_5$	$s_2 \rightarrow s_4$	$s_2 \rightarrow s_5$	$s_3 \rightarrow s_4$	$s_3 \rightarrow s_5$	$s_4 \rightarrow s_5$
Sex	Male vs Female	0.71 (0.55–0.90)	1.25 (1.08–1.45)	1.01 (0.49–2.05)	1.29 (0.89–1.87)	0.46 (0.12–1.84)	0.97 (0.70–1.34)	0.56 (0.22–1.46)	1.19 (0.56–2.55)
Age (in years)	–	1.06 (1.04–1.07)	1.02 (1.01–1.03)	1.01 (0.95–1.07)	1.01 (0.99–1.03)	1.03 (0.95–1.11)	1.03 (1.01–1.05)	1.08 (1.01–1.15)	1.06 (1.02–1.11)
Skin color	Non-white vs White	1.26 (0.99–1.60)	1.17 (1.02–1.35)	2.29 (1.14–4.62)	0.86 (0.59–1.25)	1.63 (0.43–6.17)	1.22 (0.90–1.66)	1.11 (0.42–2.92)	0.97 (0.45–2.07)
Education	High School or more vs Less than High School	0.62 (0.49–0.80)	0.94 (0.82–1.08)	0.35 (0.16–0.75)	1.12 (0.78–1.63)	0.48 (0.10–2.33)	0.96 (0.71–1.30)	0.89 (0.34–2.30)	0.69 (0.32–1.48)
CD4 nadir (cells/mm <sup>3</sup> )	<50 vs 50–200	1.65 (1.16–2.36)	1.40 (1.15–1.71)	1.76 (0.68–4.57)	0.72 (0.41–1.25)	1.95 (0.32–12.02)	1.85 (1.22–2.82)	1.80 (0.40–8.04)	0.76 (0.23–2.52)
	>200 vs 50–200	1.09 (0.82–1.44)	0.89 (0.76–1.03)	0.83 (0.38–1.80)	0.71 (0.47–1.08)	0.81 (0.15–4.44)	1.04 (0.73–1.49)	1.72 (0.54–5.47)	1.07 (0.46–2.05)
Use of ARVs related to CVD >180 days	Yes vs No	0.89 (0.28–2.76)	0.56 (0.25–1.26)	5.21 (1.24–21.84)	0.93 (0.58–1.49)	1.23 (0.25–5.93)	0.88 (0.61–1.26)	1.24 (0.44–3.52)	0.73 (0.31–1.70)

Notes: Crude HR = Hazard Ratio in single covariate multi-state models;  $s_1$ =No Comorbidities,  $s_2$ =Hypertension,  $s_3$ =Lipid Abnormalities (Dyslipidemia or Lipodystrophy),  $s_4 = s_2 + s_3$ ,  $s_5$ = CVD or stroke or thrombosis or death. Values in bold indicate  $p$ -values <0.05.

**Table 3.** Multi-covariate Semi-Markov model to major cardiovascular events progression in 1135 HIV+ individuals. Rio de Janeiro, Brazil (1996–2010).

Variables	Categories	Adjusted HR <sup>a</sup> (IC95%)							
		$s_1 \rightarrow s_2$	$s_1 \rightarrow s_3$	$s_1 \rightarrow s_5$	$s_2 \rightarrow s_4$	$s_2 \rightarrow s_5$	$s_3 \rightarrow s_4$	$s_3 \rightarrow s_5$	$s_4 \rightarrow s_5$
Sex	Male vs Female	0.75 (0.58–0.97)	1.30 (1.11–1.51)	1.48 (0.70–3.13)	1.19 (0.80–1.78)	0.41 (0.09–1.88)	0.99 (0.71–1.40)	0.54 (0.20–1.46)	1.43 (0.62–3.28)
Age (in years)	–	1.06 (1.05–1.07)	1.02 (1.01–1.03)	1.00 (0.94–1.06)	1.01 (0.99–1.03)	1.05 (0.96–1.15)	1.03 (1.01–1.04)	1.08 (1.01–1.16)	1.07 (1.02–1.11)
Skin color	Non-white vs White	1.09 (0.84–1.40)	1.16 (1.01–1.34)	2.06 (1.98–4.30)	0.91 (0.62–1.34)	1.18 (0.26–5.44)	1.19 (0.86–1.65)	0.98 (0.35–2.77)	0.72 (0.33–1.60)
Education	High School or more vs Less than High School	0.74 (0.57–0.97)	0.92 (0.80–1.07)	0.37 (0.17–0.83)	1.09 (0.74–1.61)	0.47 (0.09–2.49)	1.16 (0.83–1.61)	1.43 (0.50–4.09)	0.60 (0.26–1.37)
CD4 nadir (cells/mm <sup>3</sup> )	<50 vs 50–200	1.59 (1.11–2.28)	1.36 (1.11–1.66)	1.16 (0.43–3.15)	0.72 (0.41–1.27)	2.27 (0.30–17.16)	1.75 (1.13–2.70)	1.63 (0.19–7.68)	0.70 (0.21–2.39)
	>200 vs 50–200	1.16 (0.87–1.54)	0.91 (0.78–1.07)	0.82 (0.37–1.81)	0.78 (0.49–1.24)	0.32 (0.04–2.48)	1.14 (0.79–1.64)	2.09 (0.65–6.78)	1.32 (0.54–3.26)
Use of ARVs related to CVD >180 days	Yes vs No	0.58 (0.18–1.81)	0.46 (0.21–1.03)	5.29 (1.16–24.05)	0.98 (0.59–1.61)	1.35 (0.25–7.26)	0.86 (0.60–1.25)	1.11 (0.38–3.22)	0.92 (0.38–2.24)

Notes: Adjusted HR = Hazard Ratio in multi-covariate multi-state models;  $s_1$ =No comorbidities,  $s_2$ =Hypertension,  $s_3$ =Lipid Abnormalities (Dyslipidemia or Lipodystrophy),  $s_4 = s_2 + s_3$ ,  $s_5$ = CVD or stroke or thrombosis or death. Values in bold indicate  $p$ -values <0.05.

<sup>a</sup>Adjusted by hospitalization, use of prophylaxis for opportunistic diseases and participation in clinical trials.

In the analysis of traditional CVD risk factors (sex, age, skin color and education), our results are consistent with previous studies (Albuquerque et al., 2013; Brignol, Dourado, Amorim, & Kerr, 2015; Malta et al., 2015; Nam, Whittemore, Jeon, Davey-Rothwell, & Latkin, 2016; Santos et al., 2015). The HIV itself would be involved in the development of lipid abnormalities and CVD events (Arildsen et al., 2013; Islam et al., 2012; Martin-Iguacel et al., 2015; The SMART Study Group, 2006). According Albuquerque et al. (2013), the effect of low CD4 count in atherosclerosis occurs in PLHIV older than 40 years. We found an increased risk of developing hypertension and/or lipid disorders associated to lowest nadir CD4 count but no direct risk to develop major cardiovascular events or death, thus confirming the indirect influence of HIV on the clinical progression of the disease.

Regarding antiretroviral therapy, our study suggests that the use of ARVs related to CVD (abacavir, didanosine, ritonavir, lopinavir, amprenavir, and fosamprenavir) for more than 180 days was only associated to direct development of major cardiovascular events and death. These patients did not show any signs of hypertension or lipid disorders before these serious events. We highlight that the literature diverges about the mechanism responsible for increasing risk of cardiovascular events and lipid disorders in PLHIV, whether it is caused by use of individual ARVs, a particular ARV class or by the cumulative use of ARVs (Albuquerque et al., 2013; Islam et al., 2012; Reyskens & Faadiel Essop, 2014; Trevillyan et al., 2015). Previous study showed the occurrence of subclinical coronary plaque in PLHIV without previous CVD or lipid-lowering abnormalities (Zanni et al., 2014).

A reason for the absence of risk to develop lipid abnormalities and hypertension may be a better medical care during antiretroviral treatment, which may include recommendations on dietary intake, physical exercises, and the use of statins.

This study is the one that evaluates the progression of PLHIV regarding to development of cardiovascular events through previous comorbidities by multistate models. The main advantage of this model was to identify different risk factors as the development of comorbidities (lipid abnormalities and hypertension) as major cardiovascular events. Other strength of this study was the 15-year follow-up of a large cohort of 1135 PLHIV to evaluate a chronic event. Although, our study did not include latter years, as the time window is short to estimate cardiovascular events for new ARVs developed in recent years. A limitation of the study is the lack of evaluation of smoking, family history of CVD, use of statins and other factors related to metabolic syndrome

(diabetes and obesity), which are often associated to dyslipidemia or arterial hypertension (Nam et al., 2016; Wang et al., 2011). A second limitation is the fact that information on comorbidities and causes of death was retrospective, which could underestimate the number of comorbidities. Another limitation is that the close monitoring in HIV reference centers can reduce the number of individuals with major events and consequently reduces the precision of some effects involving major cardiovascular events and deaths. This study suggests the importance to design HIV specific guidelines to reduce major cardiovascular risk and related-comorbidities, since the distinct roles of HIV infection and of antiretroviral use on the development of major cardiovascular events and related comorbidities. The use of strategies to control lipid levels, such as physical activities and diet, as well as the rational use of statins could be intensified in patients with low nadir CD4 count at HAART initiation to prevent lipid abnormalities and hypertension. Due to the risk of major cardiovascular events, in the absence of lipid abnormalities and arterial hypertension, the prolonged use of certain ARV should be cautious and followed by a close monitoring via diagnostic medical imaging.

## Acknowledgments

We thank the professionals involved in the PLHIV care, the staff at the Hospital Information Service for maintaining the database and Eduardo Furtado for the proofreading service.

## Disclosure statement

No potential conflict of interest was reported by the authors.

## ORCID

Raquel de Vasconcellos Carvalhaes de Oliveira  <http://orcid.org/0000-0001-9387-8645>

Silvia Emiko Shimakura  <http://orcid.org/0000-0002-5468-2516>

Dayse Pereira Campos  <http://orcid.org/0000-0002-8965-534X>

Yara Hahr Marques Hokerberg  <http://orcid.org/0000-0001-7140-7172>

Flaviana Pavan Victoriano  <http://orcid.org/0000-0002-5149-9441>

Sayonara Ribeiro  <http://orcid.org/0000-0003-0461-9735>

Valdiléa Gonçalves Veloso  <http://orcid.org/0000-0002-6622-3165>

Beatriz Grinsztein  <http://orcid.org/0000-0003-3692-5155>

Marília Sá Carvalho  <http://orcid.org/0000-0002-9566-0284>



## References

- Albuquerque, V. M., Zírpoli, J. C., Miranda-Filho, D. B., Albuquerque, M. F., Montarroyos, U. R., Ximenes, R. A., & Lacerda, H. R. (2013). Risk factors for subclinical atherosclerosis in HIV-infected patients under and over 40 years: A case-control study. *BMC Infectious Diseases*, *13*, 274. doi:10.1186/1471-2334-13-274
- Andersen, P. K. (2002). Competing risks as a multi-state model. *Statistical Methods in Medical Research*, *11*, 203–215.
- Arildsen, H., Sørensen, K. E., Ingerslev, J. M., Østergaard, L. J., & Laursen, A. L. (2013). Endothelial dysfunction, increased inflammation, and activated coagulation in HIV-infected patients improve after initiation of highly active antiretroviral therapy. *HIV Medicine*, *14*, 1–9.
- Brignol, S., Dourado, I., Amorim, L. D., & Kerr, L. R. (2015). Vulnerability in the context of HIV and syphilis infection in a population of men who have sex with men (MSM) in Salvador, Bahia State, Brazil. *Cadernos de Saude Publica*, *31*(5), 1035–1048.
- Campos, D. P., Ribeiro, S. R., Grinsztejn, B., Veloso, V. G., Valente, J. G., Bastos, F. I., ... Gadelha, A. J. (2005). Survival of AIDS patients using two case definitions, Rio de Janeiro, Brasil, 1986–2003. *AIDS (London, England)*, *19* (Suppl.4), 22–26.
- Core Team, R. (2015). *R: A language and environment for statistical computing*. Vienna: R Foundation for Statistical Computing. Retrieved from <https://www.R-project.org/>
- D:A:D Study Group. (2008). Use of nucleoside reverse transcriptase inhibitors and risk of myocardial infarction in HIV-infected patients enrolled in the D:A:D study: A multi-cohort collaboration. *Lancet (London, England)*, *371* (9622), 1417–1426.
- Feinstein, M. J., Bahiru, E., Achenbach, C., Longenecker, C. T., Hsue, P., So-Armah, K., ... Lloyd-Jones, D. M. (2016). Patterns of cardiovascular mortality for HIV-infected adults in the United States: 1999 to 2013. *American Journal of Cardiology*, *117*, 214–220.
- Foucher, Y., Mathieu, E., Saint-Pierre, P., Durand, J. F., & Daurès, J. P. (2005). A semi-markov model based on generalized Weibull distribution with an illustration for HIV disease. *Biometrical Journal*, *47*(6), 825–833.
- Gomo, Z. A., Hakim, J. G., Walker, S. A., Tinago, W., Mandonaza, G., Kityo, C., ... DAART Team. (2014). Impact of second-line antiretroviral regimens on lipid profiles in an African setting: The DART trial sub-study. *AIDS Research and Therapy*, *11*, 32. doi:10.1186/1742-6405-11-32
- Huzurbazar, A. V. (2005). *Flowgraph models for multistate time-to-event data* (3rd ed.). New York: Wiley-Interscience.
- The INSIGHT START Study Group. (2015). Initiation of antiretroviral therapy in early asymptomatic HIV infection. *New England Journal of Medicine*, *373*, 795–807.
- Islam, F. M., Wu, J., Jansson, J., & Wilson, D. P. (2012). Relative risk of cardiovascular disease among people living with HIV: A systematic review and meta-analysis. *HIV Medicine*, *13*, 453–468.
- Josephson, F. (2010). Drug–drug interactions in the treatment of HIV infection: Focus on pharmacokinetic enhancement through CYP3A inhibition. *Journal of Internal Medicine*, *268*(6), 530–539.
- Kousignian, I., Abgrall, S., Duval, X., Descamps, D., Matheron, S., & Costagliola, D. (2003). Modeling the time course of CD4 T-lymphocyte counts according to the level of virologic rebound in HIV-1-infected patients on highly active antiretroviral therapy. *Journal of Acquired Immune Deficiency Syndromes*, *34*(1), 50–55.
- Lawless, J. F., & Rad, N. N. (2015). Estimation and assessment of markov multistate models with intermittent observations on individuals. *Lifetime Data Analysis*, *21*, 160–179.
- Malta, M., Silva, C. M., Magnanini, M. M., Wirtz, A. L., Perissé, A. R., Beyrer, C., ... Bastos, F. I. (2015). Improvement of HAART in Brazil, 1998–2008: A nationwide assessment of survival times after AIDS diagnosis among men who have sex with men. *BMC Public Health*, *15*, 226. doi:10.1186/s12889-015-1530-y
- Martin-Iguacel, R., Llibre, J. M., & Friis-Moller, N. (2015). Risk of cardiovascular disease in an aging HIV population: Where Are We Now? *Current HIV/AIDS Reports*, *12*, 375–387.
- Mathieu, E., Foucher, Y., Dellamonica, P., & Daurès, J. P. (2007). Parametric and non-homogeneous semi-markov process for HIV control. *Methodology Computing in Applied Probability*, *9*(3), 389–397.
- Ministério da Saúde. (2008). *Recomendações para terapia anti-retroviral em adultos infectados pelo HIV*. Brasília: Ministério da Saúde, Secretaria de Vigilância em Saúde, Programa Nacional de DST e AIDS.
- Nam, S., Whittemore, R., Jeon, S., Davey-Rothwell, M. A., & Latkin, C. (2016). High blood pressure and related factors among individuals at high risk for HIV/sexually transmitted infections. *The Journal of Clinical Hypertension (Greenwich)*, *18*(6), 572–580.
- Negredo, E., Massanella, M., Puig, J., Pérez-Alvarez, N., Gallego-Escuredo, J. M., Villaroya, J., ... Blanco, J. (2010). Nadir CD4T cell count as predictor and high CD4T cell intrinsic apoptosis as final mechanism of poor CD4T cell recovery in virologically suppressed HIV-infected patients: Clinical implications. *Clinical Infectious Diseases*, *50*(9), 1300–1308. doi:10.1086/651689
- Oliveira, R. V., Shimakura, S. E., Campos, D. P., Victoriano, F. P., Ribeiro, S. R., Veloso, V. G., ... Carvalho, M. S. (2013). Multi-state models for defining degrees of chronicity related to HIV-infected patient therapy adherence. *Cadernos de Saude Publica*, *29*(4), 801–811.
- Paisible, A., Chang, C. H., So-Armah, K. A., Butt, A. A., Leaf, D. A., Budoff, M., ... VACS Project Team. (2015). HIV infection, cardiovascular disease risk factor profile, and risk for acute myocardial infarction. *Journal of Acquired Immune Deficiency Syndromes*, *68*(2), 209–216.
- Reyskens, K. M., & Faadiel Essop, M. (2014). HIV protease inhibitors and onset of cardiovascular diseases: A central role for oxidative stress and dysregulation of the ubiquitin–proteasome system. *Biochimica et Biophysica Acta*, *1842*, 256–268.
- Santos, I. S., Alencar, A. P., Rundek, T., Goulart, A. C., Barreto, S. M., Pereira, A. C., ... Lotufo, P. A. (2015). Low impact of traditional risk factors on carotid intima-Media thickness The ELSA-brasil cohort. *Arteriosclerosis, Thrombosis, and Vascular Biology*, *35*, 2054–2059.
- The SMART Study Group. (2006). CD4+ count-guided interruption of antiretroviral treatment. *New England Journal of Medicine*, *355*, 2283–2296.
- Titman, A. C., & Sharples, L. D. (2010). Model diagnostics in multi-state models. *Statistical Methods in Medical Research*, *19*(6), 621–651.

- Trevillyan, J. M., Arthur, J. F., Jing, J., Andrews, R. K., Gardiner, E. E., & Hoy, J. F. (2015). Effects of Abacavir administration on structural and functional markers of platelet activation. *Aids (london, England)*, 29, 2309–2313.
- Triant, V. A., Lee, H., Hadigan, C., & Grinspoon, S. K. (2007). Increased acute myocardial infarction rates and cardiovascular risk factors among patients with human immunodeficiency virus disease. *The Journal of Clinical Endocrinology & Metabolism*, 92(7), 2506–2512.
- Triant, V. A. (2012). HIV infection and coronary heart disease: An intersection of epidemics. *The Journal of Infectious Diseases*, 205(Suppl 3), S355–S361.
- Wang, S., Xu, L., Jonas, J. B., You, Q. S., Wang, Y. X., & Yang, H. (2011). Prevalence and associated factors of dyslipidemia in the adult Chinese population. *PLoS One*, 6(3), e17326. doi:10.1371/journal.pone.0017326
- WHO. (2003). 2003 world health organization (WHO)/international society of hypertension (ISH) statement on management of hypertension. *Journal of Hypertension*, 21(11), 1983–1992.
- WHO. (2006). *Antiretroviral therapy for HIV infection in adults and adolescents : Recommendations for a public health approach - 2006 rev.* Geneva: WHO, HTM/HIV.
- Wreede, L. C., Fiocco, M., & Putter, H. (2011). Mstate: An R package for the analysis of competing risks an multi-state models. *Journal of Statistical Software*, 38(7), 1–30.
- Zanni, M. V., Fitch, K. V., Feldpausch, M., Han, A., Lee, H., Lu, M. T., ... Grinspoon, S. K. (2014). 2013 ACC/AHA and 2004 ATP III cholesterol guidelines applied to HIV-infected patients with/without subclinical high risk coronary plaque. *Aids (london, England)*, 28(14), 2061–2070.